

Chapter 4

STRAIGHTNESS ON CYLINDERS AND CONES

If a cut were made through a cone parallel to its base, how should we conceive of the two opposing surfaces which the cut has produced — as equal or as unequal? If they are unequal, that would imply that a cone is composed of many breaks and protrusions like steps. On the other hand if they are equal, that would imply that two adjacent intersection planes are equal, which would mean that the cone, being made up of equal rather than unequal circles, must have the same appearance as a cylinder; which is utterly absurd.

— Democritus of Abdera (~460 – ~380 B.C.)

This quote shows that cylinders and cones were the subject of mathematical inquiry before Euclid (~365 – ~300 B.C.). In this chapter we investigate straightness on cones and cylinders. You should be comfortable with straightness as a *local intrinsic notion* — this is the bug’s view. This notion of straightness is also the basis for the notion of *geodesics* in differential geometry. Chapters 4 and 5 can be covered in either order, but we think that the experience with cylinders and cones in **4.1** will help the reader to understand the hyperbolic plane in **5.1**. If the reader is comfortable with straightness as a local intrinsic notion, then it is also possible to skip Chapter 4 if Chapters 18 and 24 on geometric manifolds are not going to be covered. However, we suggest that you read the sections at the end of this chapter — Is “Shortest” Always “Straight”? and Relations to Differential Geometry — at least enough to find out what Euclid’s Fourth Postulate (see Appendix A) has to do with cones and cylinders.

When looking at great circles on the surface of a sphere, we were able (except in the case of central symmetry) to see all the symmetries of straight lines from global extrinsic points of view. For example, a great circle extrinsically divides a sphere into two hemispheres that are mirror images of each other. Thus on a sphere, it is a natural tendency to use the more familiar and comfortable extrinsic lens instead of taking the bug's local and intrinsic point of view. However, on a cone and cylinder you must use the local, intrinsic point of view because there is no extrinsic view that will work except in special cases.

PROBLEM 4.1 STRAIGHTNESS ON CYLINDERS AND CONES

- a. *What lines are straight with respect to the surface of a cylinder or a cone? Why? Why not?*
- b. *Examine:*
 - ♦ *Can geodesics intersect themselves on cylinders and cones?*
 - ♦ *Can there be more than one geodesic joining two points on cylinders and cones?*
 - ♦ *What happens on cones with varying cone angles, including cone angles greater than 360° ? These are discussed starting in the next section.*

SUGGESTIONS

Problem 4.1 is similar to Problem 2.1, but this time the surfaces are cylinders and cones.

Make paper models, but consider the cone or cylinder as continuing indefinitely with no top or bottom (except, of course, at the cone point). Again, imagine yourself as a bug whose whole universe is a cone or cylinder. As the bug crawls around on one of these surfaces, what will the bug experience as straight? As before, paths that are straight with respect to a surface are often called the "geodesic" for the surface.

As you begin to explore these questions, it is likely that many other related geometric ideas will arise. Do not let seemingly irrelevant excess geometric baggage worry you. Often, you will find yourself getting lost in a tangential idea, and that's understandable. Ultimately, however, the

exploration of related ideas will give you a richer understanding of the scope and depth of the problem. In order to work through possible confusion on this problem, try some of the following suggestions others have found helpful. Each suggestion involves constructing or using models of cones and cylinders.

- ◆ You may find it helpful to explore cylinders first before beginning to explore cones. This problem has many aspects, but focusing at first on the cylinder will simplify some things.
- ◆ If we make a cone or cylinder by rolling up a sheet of paper, will “straight” stay the same for the bug when we unroll it? Conversely, if we have a straight line drawn on a sheet of paper and roll it up, will it continue to be experienced as straight for the bug crawling on the paper? *We are assuming here that the paper will not stretch and its thickness is negligible.*
- ◆ Lay a stiff ribbon or straight strip of paper on a cylinder or cone. Convince yourself that it will follow a straight line with respect to the surface. Also, convince yourself that straight lines on the cylinder or cone, *when looked at locally and intrinsically*, have the same symmetries as on the plane.
- ◆ If you intersect a cylinder by a flat plane and unroll it, what kind of curve do you get? Is it ever straight? (One way to see this curve is to dip a paper cylinder into water.)
- ◆ On a cylinder or cone, can a geodesic ever intersect itself? How many times? This question is explored in more detail in Problem 4.2, which the interested reader may turn to now.
- ◆ Can there be more than one geodesic joining two points on a cylinder or cone? How many? Is there always at least one? Again this question is explored in more detail in Problem 4.2.

There are several important things to keep in mind while working on this problem. First, **you absolutely must make models**. If you attempt to visualize lines on a cone or cylinder, you are bound to make claims that you would easily see are mistaken if you investigated them on an actual

cone or cylinder. Many students find it helpful to make models using transparencies.

Second, as with the sphere, you must think about lines and triangles on the cone and cylinder in an intrinsic way — always looking at things from a bug's point of view. We are not interested in what's happening in 3-space, only what you would see and experience if you were restricted to the surface of a cone or cylinder.

And last, but certainly not least, you must look at cones of different shapes, that is, cones with varying cone angles.

CONES WITH VARYING CONE ANGLES

Geodesics behave differently on differently shaped cones. So an important variable is the cone angle. The *cone angle* is generally defined as the angle measured around the point of the cone on the surface. Notice that this is an intrinsic description of angle. The bug could measure a cone angle (in radians) by determining the circumference of an intrinsic circle with center at the cone point and then dividing that circumference by the radius of the circle. We can determine the cone angle extrinsically in the following way: Cut the cone along a *generator* (a line on the cone through the cone point) and flatten the cone. The measure of the cone angle is then the angle measure of the flattened planar sector.

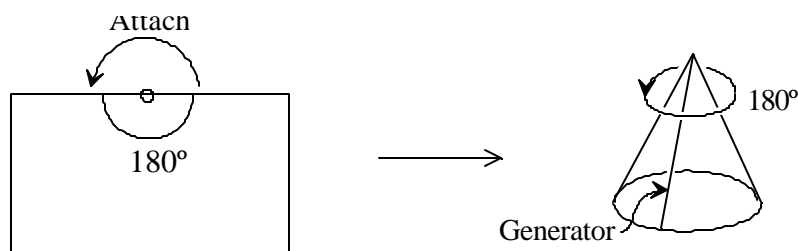

Figure 4.1 Making a 180° cone

For example, if we take a piece of paper and bend it so that half of one side meets up with the other half of the same side, we will have a 180-degree cone (Figure 4.1). A 90° cone is also easy to make — just use the corner of a paper sheet and bring one side around to meet the adjacent side.

Also be sure to look at larger cones. One convenient way to do this is to make a cone with a variable cone angle. This can be accomplished

by taking a sheet of paper and cutting (or tearing) a slit from one edge to the center. (See Figure 4.2.) A rectangular sheet will work but a circular sheet is easier to picture. Note that it is not necessary that the slit be straight!

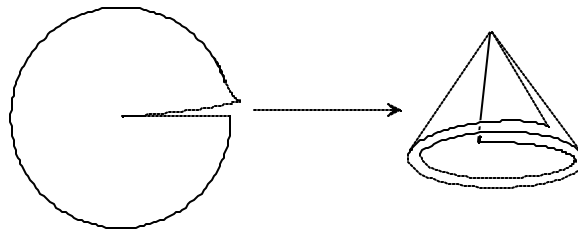

Figure 4.2 A cone with variable cone angle ($0-360^\circ$)

You have already looked at a 360° cone — it's just a plane. The cone angle can also be larger than 360° . A common larger cone is the 450° cone. You probably have a cone like this somewhere on the walls, floor, and ceiling of your room. You can easily make one by cutting a slit in a piece of paper and inserting a 90° slice ($360^\circ + 90^\circ = 450^\circ$) as in Figure 4.3.

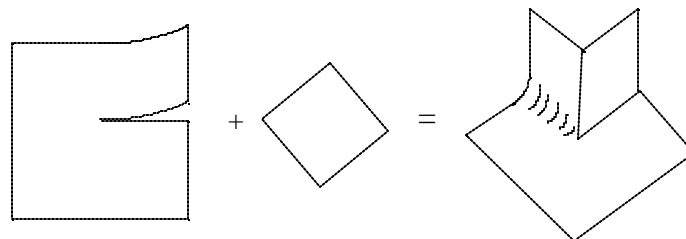

Figure 4.3 How to make a 450° cone

You may have trouble believing that this is a cone, but remember that just because it cannot hold ice cream does not mean it is not a cone. If the folds and creases bother you, they can be taken out — the cone will look ruffled instead. It is important to realize that when you change the shape of the cone like this (that is, by ruffling), you are only changing its extrinsic appearance. Intrinsically (from the bug's point of view) there is no difference. You can even ruffle the cone so that it will hold ice cream if you like, although changing the extrinsic shape in this way is not useful to a study of its intrinsic behavior.

It may be helpful for you to discuss some definitions of a cone, such as the following: Take any simple (non-intersecting) closed curve a on a sphere and the center P of the sphere. A **cone** is the union of the rays that start at P and go through each point on a . The cone angle is then equal to (length of a)/(radius of sphere), in radians. Do you see why?

You can also make a cone with variable angle of more than 180° : Take two sheets of paper and slit them together to their centers as in Figure 4.4. Tape the right side of the top slit to the left side of the bottom slit as pictured. Now slide the other sides of the slits. Try it!

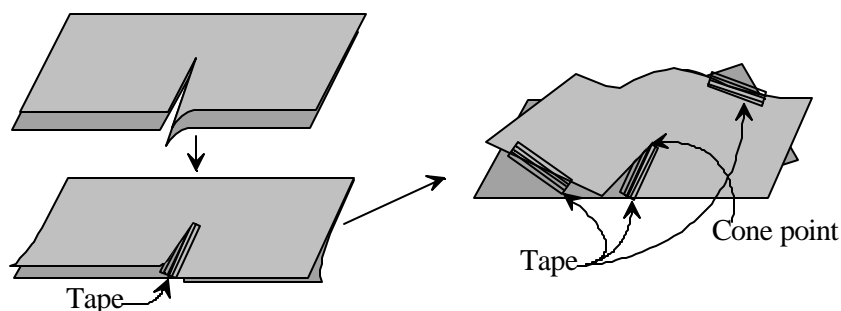



Figure 4.4 Variable cone angle larger than 360°

Experiment by making paper examples of cones like those shown in Figure 4.4. What happens to the triangles and lines on a 450° cone? Is the shortest path always straight? Does every pair of points determine a straight line?

Finally, also consider line symmetries on the cone and cylinder. Check to see if the symmetries you found on the plane will work on these surfaces, and remember to think intrinsically and locally. A special class of geodesics on the cone and cylinder are the generators. These are the straight lines that go through the cone point on the cone or go parallel to the axis of the cylinder. These lines have some extrinsic symmetries (*can you see which ones?*), but in general, geodesics have only local, intrinsic symmetries. Also, on the cone, think about the region near the cone point — what is happening there that makes it different from the rest of the cone?

 **It is best if you experiment with paper models to find out what geodesics look like on the cone and cylinder before reading further.**

GEODESICS ON CYLINDERS

Let us first look at the three classes of straight lines on a cylinder. When walking on the surface of a cylinder, a bug might walk along a vertical generator. See Figure 4.5.

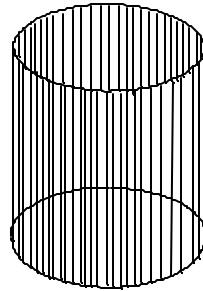

Figure 4.5 Vertical generators are straight

It might walk along an intersection of a horizontal plane with the cylinder, what we will call a *great circle*. See Figure 4.6

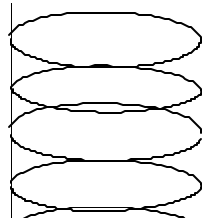

Figure 4.6 Great circles are intrinsically straight

Or, the bug might walk along a spiral or helix of constant slope around the cylinder. See Figure 4.7.