

**Partition identity bijections  
related to sign-balance and rank**

by

Cilanne Emily Boulet

BMath, University of Waterloo, 2001

Submitted to the Department of Mathematics  
in partial fulfillment of the requirements for the degree of

Doctor of Philosophy

at the

MASSACHUSETTS INSTITUTE OF TECHNOLOGY

June 2005

© Cilanne Emily Boulet, MMV. All rights reserved.

The author hereby grants to MIT permission to reproduce and  
distribute publicly paper and electronic copies of this thesis document  
in whole or in part.

Author .....  
Department of Mathematics  
April 26, 2005

Certified by .....  
Richard P. Stanley  
Norman Levinson Professor of Applied Mathematics  
Thesis Supervisor

Accepted by .....  
Rodolfo Ruben Rosales  
Chairman, Applied Mathematics Committee

Accepted by .....  
Pavel I. Etingof  
Chairman, Department Committee on Graduate Students



# Partition identity bijections related to sign-balance and rank

by  
Cilanne Emily Boulet

Submitted to the Department of Mathematics  
on April 26, 2005, in partial fulfillment of the  
requirements for the degree of  
Doctor of Philosophy

## Abstract

In this thesis, we present bijections proving partitions identities.

In the first part, we generalize Dyson's definition of rank to partitions with successive Durfee squares. We then present two symmetries for this new rank which we prove using bijections generalizing conjugation and Dyson's map. Using these two symmetries we derive a version of Schur's identity for partitions with successive Durfee squares and Andrews' generalization of the Rogers-Ramanujan identities. This gives a new combinatorial proof of the first Rogers-Ramanujan identity. We also relate this work to Garvan's generalization of rank.

In the second part, we prove a family of four-parameter partition identities which generalize Andrews' product formula for the generating function for partitions with respect number of odd parts and number of odd parts of the conjugate. The parameters which we use are related to Stanley's work on the sign-balance of a partition.

Thesis Supervisor: Richard P. Stanley

Title: Norman Levinson Professor of Applied Mathematics



## Acknowledgments

First let me begin by thanking my advisor, Richard Stanley. His knowledge is truly awe-inspiring and I feel lucky to be his student. I really appreciate the support and advice I have received from him over the past four year and I hope this will not stop when I am no longer at MIT.

In addition I want to thank Igor Pak; our mathematical discussions and collaboration have been particularly useful. My interest in combinatorics started at the University of Waterloo thanks to Ian Goulden, David Jackson, and David Wagner and I am thankful for their continued encouragement. Others that deserve a special mention include Alex Postnikov for very interesting classes and Ira Gessel for a careful reading of my thesis.

One of the many surprising things I found myself doing at here was collaborating with a political scientist. Working with Kanchan Chandra has been and continues to be a great pleasure.

While at MIT I have been surrounded by many incredible people: Wai Ling, Yvonne, Benoit, Francis, Evelyne, Bridget, Lauren, Sergi, Thomas, Nataša, Nenad, Frédéric, Silvia, and Aftab. They have been great friends and my memories of my time here will be better because they have been a part of it. Among these people, Bridget deserves a special thanks for proofreading this thesis and providing encouragement just when I needed it.

I must also mention my friends from Waterloo and Winnipeg, in particular Joel, Soroosh, Sam and Leah, Kate, Margaret, Yaacov, and Shona, on whose support I could count even though they have dispersed all over the continent.

Lianne has been a terrific friend for so many years. No matter what is going on, whether I am happy or sad, I know that I can always count on her to listen and care.

There are also my parents, Joyce and Denis Boulet, and my brother, Erik. They never pushed me to study for this long but were always proud of me and figured that I could do it even when I was not completely sure I could.

Finally, I do not know where to start thanking Etienne and so I simply thank him for everything.



# Contents

<b>1</b>	<b>Introduction</b>	<b>9</b>
1.1	Basic definitions and notations . . . . .	9
1.2	The Rogers-Ramanujan identities . . . . .	11
1.3	A four-parameter partition identity . . . . .	12
<b>2</b>	<b>The first Rogers-Ramanujan identity</b>	<b>13</b>
2.1	The algebraic part . . . . .	13
2.2	The combinatorial part . . . . .	16
2.2.1	Definition of rank . . . . .	16
2.2.2	Proof of the first symmetry . . . . .	17
2.2.3	Proof of the second symmetry . . . . .	20
<b>3</b>	<b>Generalized Rogers-Ramanujan identities: preliminaries and definitions</b>	<b>25</b>
3.1	First step: Schur's identity . . . . .	25
3.2	Successive Durfee rectangles . . . . .	26
3.3	Definition of $(k, m)$ -rank . . . . .	28
3.4	Symmetries . . . . .	31
3.5	Algebraic derivation of Schur's identity . . . . .	32
<b>4</b>	<b>Symmetries for <math>(k, m)</math>-rank</b>	<b>35</b>
4.1	Selection and insertion . . . . .	35
4.2	First symmetry . . . . .	43

4.3	Second symmetry . . . . .	47
<b>5</b>	<b>Connections to other work and further questions</b>	<b>53</b>
5.1	Dyson's rank and proof of Euler's pentagonal number theorem . . . . .	53
5.2	Garvan and Berkovich . . . . .	56
5.2.1	Equidistribution of $r_{k,0}$ and $gr_k$ . . . . .	56
5.2.2	Conjugation . . . . .	61
5.2.3	Dyson's map . . . . .	62
5.3	Bressoud and Zeilberger . . . . .	62
5.4	Further questions . . . . .	63
<b>6</b>	<b>A four-parameter partition identity</b>	<b>65</b>
6.1	Main result . . . . .	65
6.2	Bijjective proof of Theorem 6.1.3 . . . . .	67
<b>A</b>	<b>Other applications of insertion</b>	<b>71</b>
A.1	Formula for the $q$ -binomial coefficient . . . . .	71
A.2	Generating function for partitions with successive Durfee squares . . . . .	72
<b>B</b>	<b>Franklin's bijection</b>	<b>75</b>

# Chapter 1

## Introduction

### 1.1 Basic definitions and notations

Before introducing the partition bijections which will be proved in this thesis, we begin by giving the basic definitions that we will need. This section is meant simply to familiarize the reader with the notation that will be used, rather than provide an introduction to the subject. For such an introduction we recommend [And76, Pak05].

A *partition*  $\lambda$  is a sequence of integers  $(\lambda_1, \lambda_2, \dots, \lambda_\ell)$  such that  $\lambda_1 \geq \lambda_2 \geq \dots \geq \lambda_\ell > 0$ . As a convention, we will say that  $\lambda_j = 0$  for  $j > \ell$ . For  $1 \leq i \leq \ell$ , we call each  $\lambda_i$  a *part* of  $\lambda$ . We say that  $\lambda$  is a partition of  $n$ , denoted  $\lambda \vdash n$  or  $|\lambda| = n$ , if  $\sum \lambda_i = n$ . Let  $\mathcal{P}_n$  denote the set of partitions of  $n$  and let  $p(n) = |\mathcal{P}_n|$ . Also, let  $\mathcal{P} = \cup_n \mathcal{P}_n$  denote the set of all partitions.

We let  $\ell(\lambda) = \ell$  denote the *number of parts* of  $\lambda$ , let  $f(\lambda) = \lambda_1$  denote the *largest part* of  $\lambda$ , and let  $e(\lambda) = \lambda_{\ell(\lambda)}$  denote the *smallest part* of  $\lambda$ . Finally, let  $\theta(\lambda)$  denote the *number of odd parts* of  $\lambda$ .

To every partition we associate a *Young diagram* as in Figure 1-1.

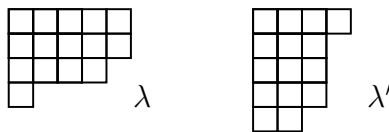

Figure 1-1: Partition  $\lambda = (5, 5, 4, 1)$  and conjugate partition  $\lambda' = (4, 3, 3, 3, 2)$ .

The *conjugate*  $\lambda'$  of a partition  $\lambda$  is obtained by reflection across the main diagonal (again see Figure 1-1). Alternatively,  $\lambda'$  may be defined as follows:  $\lambda' = (\lambda'_1, \lambda'_2, \dots, \lambda'_{f(\lambda)})$  where  $\lambda'_i = |\{j : \lambda_j \geq i\}|$  be the number of parts of  $\lambda$  which are greater than or equal to  $i$ .

The *Durfee square* of a partition  $\lambda$  is the largest square which fits in the Young diagram of  $\lambda$ . Note that conjugation preserves the Durfee square of a partition. See Figure 1-2.

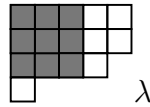

Figure 1-2: Partition  $\lambda = (5, 5, 4, 1)$  has a Durfee square of size 3.

For every pair of partitions,  $\lambda$  and  $\mu$ , we define two new partitions. The *sum* of  $\lambda$  and  $\mu$ ,  $\lambda + \mu$ , is the partition whose parts are  $(\lambda_1 + \mu_1, \lambda_2 + \mu_2, \dots)$ . The *union* of  $\lambda$  and  $\mu$ ,  $\lambda \cup \mu$ , is the partition with parts  $\{\lambda_1, \lambda_2, \dots, \mu_1, \mu_2, \dots\}$  arranged in non-increasing order. Note that  $\lambda \cup \mu = (\lambda' + \mu)'$ . See Figure 1-3.

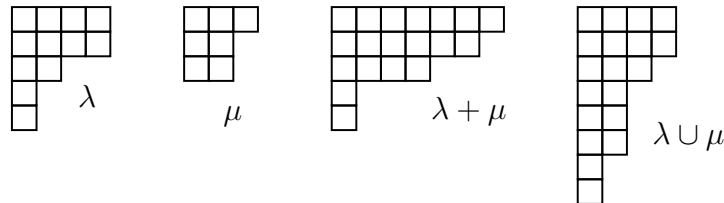

Figure 1-3: Sum and union:  $\lambda = (4, 4, 2, 1, 1)$ ,  $\mu = (3, 2, 2)$ ,  $\lambda + \mu = (7, 6, 4, 1, 1)$ ,  $\lambda \cup \mu = (4, 4, 3, 2, 2, 2, 1, 1)$ .

We will use standard  $q$ -series notation to write the various generating functions in which we are interested. Following [And76], let

$$(a)_k = (a; q)_k = (1 - a)(1 - aq) \cdots (1 - aq^{k-1}) = \prod_{j=0}^{k-1} (1 - aq^j)$$

and

$$(a)_\infty = (a; q)_\infty = \lim_{k \rightarrow \infty} (a; q)_k = \prod_{j=0}^{\infty} (1 - aq^j).$$

The generating function for  $\mathcal{P}$ , the set of all partitions, is

$$\sum_{n=0}^{\infty} p(n)q^n = \frac{1}{(q)_\infty} = \prod_{k=1}^{\infty} \frac{1}{(1 - q^k)}.$$

Similarly, the generating function for the set of all partitions with parts of size at most  $k$  is

$$\frac{1}{(q)_k} = \frac{1}{(1 - q)(1 - q^2) \cdots (1 - q^k)}.$$

By conjugation, this is also the generating function for partitions with at most  $k$  parts.

Finally, let  $\left[ \begin{smallmatrix} k+j \\ k \end{smallmatrix} \right]_q$  denote the generating function for partitions with parts of size at most  $k$  and at most  $j$  parts, i.e. partitions that fit into a  $j \times k$  box. Then we have

$$\left[ \begin{smallmatrix} k+j \\ k \end{smallmatrix} \right]_q = \frac{(q)_{k+j}}{(q)_k(q)_j}. \quad (1.1)$$

This fact can be established in a variety of ways but is not completely trivial to establish by direct bijection. One bijective proof was found by Zeilberger [BZ89]. We will explain this bijection in Appendix A. Another bijective proof of this identity was found by Franklin [SF82] and will be useful in Chapter 5. We will explain Franklin’s proof in Appendix B.

## 1.2 The Rogers-Ramanujan identities

The Roger-Ramanujan identities are perhaps the most mysterious and celebrated results in partition theory. They have a remarkable tenacity to appear in areas as distinct as enumerative combinatorics, number theory, representation theory, group theory, statistical physics, probability and complex analysis [And76, And86]. The identities were discovered independently by Rogers, Schur, and Ramanujan (in this order), but were named and publicized by Hardy [Har40]. Since then, the identities have been greatly romanticized and have achieved nearly royal status in the field. By now there are dozens of proofs known, of various degree of difficulty and depth. Still, it seems that Hardy’s famous comment remain valid: “*None of the proofs of [the Rogers-Ramanujan identities] can be called “simple” and “straightforward” [...]; and no doubt it would be unreasonable to expect a really easy proof*” [Har40].

Of the many proofs of Rogers-Ramanujan identities only a few can be honestly called “combinatorial”. We would like to single out [And75] as an interesting example. Perhaps, the most important combinatorial proof was given by Schur in [Sch17] where he deduced his identity by a direct involutive argument. The celebrated bijection of Garsia and Milne [GM81] is based on this proof and the involution principle. In [BZ82], Bressoud and Zeilberger obtained a different involution principle proof (see also [BZ89]) based on a short proof of Bressoud [Bre83].

In the second chapter of this thesis we propose a new combinatorial proof of the first Rogers-Ramanujan identity,

$$1 + \sum_{k=1}^{\infty} \frac{q^{k^2}}{(1-q)(1-q^2)\cdots(1-q^k)} = \prod_{i=0}^{\infty} \frac{1}{(1-q^{5i+1})(1-q^{5i+4})},$$

with a minimum amount of algebraic manipulation (also see [BP04]). Almost com-

pletely bijective, our proof would not satisfy Hardy as it is neither “simple” nor “straightforward”. On the other hand, the heart of the proof is the analysis of two bijections and their properties, each of them elementary and approachable. Our proof gives new generating function formulas and can be modified to prove generalizations of the Rogers-Ramanujan identities due to Andrews. These results appear in Chapters 3 and 4.

The basic idea of our proof is to use a generalization of Dyson’s rank to partitions with successive Durfee squares and deduce the Rogers-Ramanujan identities using symmetries for partitions that are related to this new rank. The heart of our proof is the bijections which are used to establish these symmetries in Chapter 4.

We should mention that on the one hand, our proof is influenced by the works of Bressoud and Zeilberger [Bre83, BZ82, BZ85, BZ89], and on the other hand by Dyson’s papers [Dys44, Dys69], which were further extended by Berkovich and Garvan [Gar94, BG02] (see also [Pak03]). The idea of using iterated Durfee squares to study the Rogers-Ramanujan identities and their generalizations is due to Andrews [And79]. We will explain the connections between our bijections and the work listed above in Chapter 5.

Also, while our proof is mostly combinatorial it is by no means a direct bijection. The quest for a direct bijective proof is still under way, and as recently as this year Zeilberger lamented on the lack of such a proof [Zei05]. The results in [Pak] seem to discourage any future work in this direction.

### 1.3 A four-parameter partition identity

In his study of the sign-balance of posets [Sta04], Stanley presented a simple generating function related to the statistic  $\frac{1}{2}(\theta(\lambda) - \theta(\lambda'))$ . This also appears as an American Mathematical Monthly problem [Sta02]. Motivated by this problem, Andrews gave a simple product formula for the generating function for partitions with respect to size, number of odd parts, and number of odd parts of the conjugate,

$$\sum_{\lambda \in \mathcal{P}} r^{\theta(\lambda)} s^{\theta(\lambda')} q^{|\lambda|} = \prod_{j=1}^{\infty} \frac{(1 + rsq^{2j-1})}{(1 - q^{4j})(1 - r^2q^{4j-2})(1 - s^2q^{4j-2})}, \quad (1.2)$$

and asked for a combinatorial proof.

In Chapter 6, we present a generalization of this identity which incorporates a fourth parameter (see also [Bou05]). We also determine the corresponding generating functions for other sets of partitions, including the set of partitions with distinct parts, and we prove all of these identities by simple bijections. Other combinatorial proofs of Andrews’ result have been found by Sills [Sil04] and Yee [Yee04].

# Chapter 2

## The first Rogers-Ramanujan identity

In this chapter, we give a combinatorial proof of the first Rogers-Ramanujan identity. This proof will be generalized in the following chapters. We include this chapter because in the case of the first Rogers-Ramanujan identity the proof can be explained more directly.

Let us say a few words about the structure of our proof. Our proof has two virtually independent parts. In the first, *the algebraic part*, we use the Jacobi triple product identity and some elementary algebraic manipulations to derive the identity. This proof is based on two symmetry equations whose proofs are given in *the combinatorial part* by direct bijections. Our presentation is completely self contained, except for the use of the classical Jacobi triple product identity.

### 2.1 The algebraic part

We consider the first *Rogers-Ramanujan identity*:

$$1 + \sum_{k=1}^{\infty} \frac{q^{k^2}}{(1-q)(1-q^2)\cdots(1-q^k)} = \prod_{i=0}^{\infty} \frac{1}{(1-q^{5i+1})(1-q^{5i+4})}. \quad (2.1)$$

Our first step is standard. Recall the *Jacobi triple product identity* (see e.g. [And76]):

$$\sum_{k=-\infty}^{\infty} z^k t^{\frac{k(k+1)}{2}} = \prod_{i=1}^{\infty} (1+zt^i) \prod_{j=0}^{\infty} (1+z^{-1}t^j) \prod_{i=1}^{\infty} (1-t^i).$$

Set  $t = q^5$ ,  $z = (-q^{-2})$ , and rewrite the right hand side of (2.1) using the Jacobi triple

product identity as follows:

$$\prod_{r=0}^{\infty} \frac{1}{(1 - q^{5r+1})(1 - q^{5r+4})} = \prod_{i=1}^{\infty} \frac{1}{(1 - q^i)} \sum_{m=-\infty}^{\infty} (-1)^m q^{\frac{m(5m-1)}{2}}.$$

This gives us *Schur's identity*, which is equivalent to (2.1):

$$\left( 1 + \sum_{k=1}^{\infty} \frac{q^{k^2}}{(1 - q)(1 - q^2) \cdots (1 - q^k)} \right) = \prod_{i=1}^{\infty} \frac{1}{(1 - q^i)} \sum_{m=-\infty}^{\infty} (-1)^m q^{\frac{m(5m-1)}{2}}. \quad (2.2)$$

We will prove Schur's identity by considering the set of partitions not counted on the left hand side of (2.2). We say that  $\lambda$  is a *Rogers-Ramanujan partition* if  $e(\lambda) \geq \ell(\lambda)$ . Recall from the introduction that these denote the smallest part of  $\lambda$  and the number of parts of  $\lambda$ . Therefore, Rogers-Ramanujan partitions are those with no parts below its Durfee square. Denote by  $\mathcal{Q}_n$  the set of Rogers-Ramanujan partitions, and let  $\mathcal{Q} = \cup_n \mathcal{Q}_n$ ,  $q(n) = |\mathcal{Q}_n|$ . Recall that the generating function for  $\mathcal{P}$  is

$$1 + \sum_{n=1}^{\infty} p(n) q^n = \prod_{i=1}^{\infty} \frac{1}{1 - q^i},$$

while the generating function for  $\mathcal{Q}$  is

$$1 + \sum_{n=1}^{\infty} q(n) q^n = 1 + \sum_{k=1}^{\infty} \frac{q^{k^2}}{(1 - q)(1 - q^2) \cdots (1 - q^k)}.$$

We consider a statistic on  $\mathcal{P} \setminus \mathcal{Q}$  which we call  $(2, 0)$ -rank of a partition, and denote by  $r_{2,0}(\lambda)$ , for  $\lambda \in \mathcal{P} \setminus \mathcal{Q}$ . Similarly, for  $m \geq 1$  we consider a statistic on  $\mathcal{P}$  which we call  $(2, m)$ -rank of a partition, and denote by  $r_{2,m}(\lambda)$ , for  $\lambda \in \mathcal{P}$ . We formally define and study these statistics in the next section. Denote by  $h(n, m, r)$  the number of partitions  $\lambda$  of  $n$  with  $r_{2,m}(\lambda) = r$ . Similarly, let  $h(n, m, \leq r)$  and  $h(n, m, \geq r)$  be the number of partitions with the  $(2, m)$ -rank at most  $r$  and at least  $r$ , respectively. The following is apparent from the definitions:

$$\begin{aligned} h(n, m, \leq r) + h(n, m, \geq r + 1) &= p(n), \text{ and for } m > 0, \\ h(n, 0, \leq r) + h(n, 0, \geq r + 1) &= p(n) - q(n), \end{aligned} \quad (2.3)$$

for all  $r \in \mathbb{Z}$  and  $n \geq 1$ . The following two equations are the main ingredients of the proof. If  $r > 0$  or  $m = 0$ , we have:

**(first symmetry)**  $h(n, 0, r) = h(n, 0, -r)$ , and

**(second symmetry)**  $h(n, m, \leq -r) = h(n - r - 2m - 2, m + 2, \geq -r)$ .

Both symmetry equations will be proved in the next section. For now, let us continue

to prove Schur's identity. For every  $j \geq 0$  let

$$a_j = h(n - jr - 2jm - j(5j - 1)/2, m + 2j, \leq -r - j),$$

$$b_j = h(n - jr - 2jm - j(5j - 1)/2, m + 2j, \geq -r - j + 1).$$

The equation (2.3) gives us  $a_j + b_j = p(n - jr - 2jm - j(5j - 1)/2)$ , for all  $r, j > 0$ . The second symmetry equation gives us  $a_j = b_{j+1}$ .

Applying these multiple times we get:

$$\begin{aligned} h(n, m, \leq -r) &= a_0 = b_1 \\ &= b_1 + (a_1 - b_2) - (a_2 - b_3) + (a_3 - b_4) - \dots \\ &= (b_1 + a_1) - (b_2 + a_2) + (b_3 + a_3) - (b_4 + a_4) + \dots \\ &= p(n - r - 2m - 2) - p(n - 2r - 4m - 9) + p(n - 3r - 6m - 42) - \dots \\ &= \sum_{j=1}^{\infty} (-1)^{j-1} p(n - jr - 2jm - j(5j - 1)/2). \end{aligned}$$

In terms of the generating functions

$$H_{m, \leq r}(q) := \sum_{n=1}^{\infty} h(n, m, \leq r) q^n,$$

this gives (if  $r > 0$  or  $m = 0$ )

$$H_{m, \leq r}(q) = \prod_{n=1}^{\infty} \frac{1}{(1 - q^n)} \sum_{j=1}^{\infty} (-1)^{j-1} q^{jr+2jm+j(5j-1)/2}. \quad (2.4)$$

In particular, we have:

$$\begin{aligned} H_{0, \leq 0}(q) &= \prod_{i=1}^{\infty} \frac{1}{(1 - q^i)} \sum_{j=1}^{\infty} (-1)^{j-1} q^{\frac{j(5j-1)}{2}} \text{ and} \\ H_{0, \leq -1}(q) &= \prod_{i=1}^{\infty} \frac{1}{(1 - q^i)} \sum_{j=1}^{\infty} (-1)^{j-1} q^{\frac{j(5j+1)}{2}}. \end{aligned}$$

From the first symmetry equation and (2.3)

$$H_{0, \leq 0}(q) + H_{0, \leq -1}(q) = H_{0, \leq 0}(q) + H_{0, \geq 1}(q)$$

is the generating function for  $\mathcal{P} \setminus \mathcal{Q}$ .

We conclude:

$$\prod_{n=1}^{\infty} \frac{1}{(1-q^n)} \left( \sum_{j=1}^{\infty} (-1)^{j-1} q^{\frac{j(5j-1)}{2}} + \sum_{j=1}^{\infty} (-1)^{j-1} q^{\frac{j(5j+1)}{2}} \right) \\ = \prod_{i=1}^{\infty} \frac{1}{(1-q^i)} - \left( 1 + \sum_{k=1}^{\infty} \frac{q^{k^2}}{(1-q)(1-q^2)\dots(1-q^k)} \right),$$

which implies (2.2) and completes the proof of (2.1).

## 2.2 The combinatorial part

### 2.2.1 Definition of rank

Define an  $m$ -rectangle to be a rectangle whose height minus its width is  $m$ . Define the *first  $m$ -Durfee rectangle* to be the largest  $m$ -rectangle which fits in the diagram of  $\lambda$ . Denote by  $s_m(\lambda)$  the height of the first  $m$ -Durfee rectangle. Define the *second  $m$ -Durfee rectangle* to be the largest  $m$ -rectangle which fits in the diagram of  $\lambda$  below the first  $m$ -Durfee rectangle, and let  $t_m(\lambda)$  be its height. We will allow an  $m$ -Durfee rectangle to have width 0 but never height 0. Finally, denote by  $\alpha$ ,  $\beta$ , and  $\gamma$  the three partitions to the right of, in the middle of, and below the two  $m$ -Durfee rectangles (see Figure 2-1).

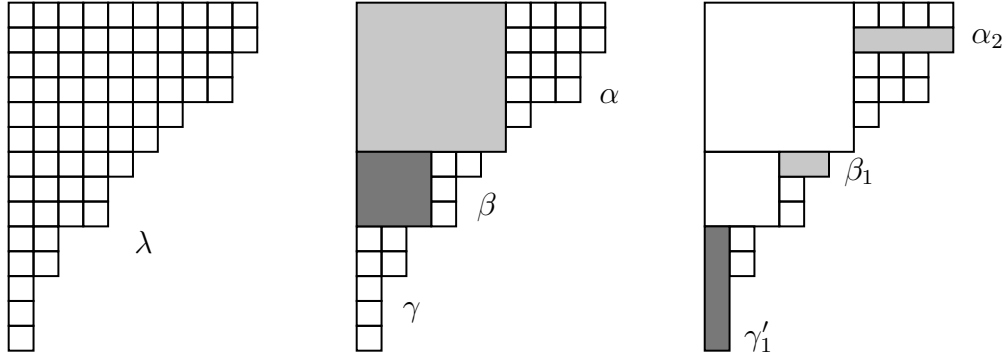

Figure 2-1: Partition  $\lambda = (10, 10, 9, 9, 7, 6, 5, 4, 4, 2, 2, 1, 1, 1)$ , the first Durfee square of height  $s_0(\lambda) = 6$ , and the second Durfee square of height  $t_0(\lambda) = 3$ . Here the remaining partitions are  $\alpha = (4, 4, 3, 3, 1)$ ,  $\beta = (2, 1, 1)$ , and  $\gamma = (2, 2, 1, 1, 1)$ .

We define  $(2, m)$ -rank,  $r_{2,m}(\lambda)$ , of a partition  $\lambda$  by the formula:

$$r_{2,m}(\lambda) := \beta_1 + \alpha_{s_m(\lambda) - t_m(\lambda) - \beta_1 + 1} - \gamma'_1.$$

For example,  $r_{2,0}(\lambda) = \beta_1 + \alpha_2 - \gamma'_1 = 2 + 4 - 5 = 1$  for  $\lambda$  as in Figure 2-1.

Note that  $(2, 0)$ -rank is only defined for non-Rogers-Ramanujan partitions because otherwise  $\beta_1$  does not exist, while  $(2, m)$ -rank is defined for all partitions for all  $m > 0$ .

Let  $\mathcal{H}_{n,m,r}$  to be the set of partitions of  $n$  with  $(2, m)$ -rank  $r$ . In the notation above,  $h(n, m, r) = |\mathcal{H}_{n,m,r}|$ . Also let  $\mathcal{H}_{n,m,\leq r}$  be the set of partitions of  $n$  with  $(2, m)$ -rank less than or equal to  $r$  and let  $\mathcal{H}_{n,m,\geq r}$  be the set of partitions of  $n$  with  $(2, m)$ -rank greater than or equal to  $r$ , so that  $h(n, m, \leq r) = |\mathcal{H}_{n,m,\leq r}|$  and  $h(n, m, \geq r) = |\mathcal{H}_{n,m,\geq r}|$ .

## 2.2.2 Proof of the first symmetry

In order to prove the first symmetry we present an involution  $\mathbf{c}$  on  $\mathcal{P} \setminus \mathcal{Q}$  which preserves the size of partitions as well as their Durfee squares, but changes the sign of the rank:

$$\mathbf{c} : \mathcal{H}_{n,0,r} \rightarrow \mathcal{H}_{n,0,-r}.$$

Let  $\lambda$  be a partition with two Durfee square and partitions  $\alpha$ ,  $\beta$ , and  $\gamma$  to the right of, in the middle of, and below the Durfee squares. This map  $\mathbf{c}$  will preserve the Durfee squares of  $\lambda$  whose sizes we denote by

$$s = s_0(\lambda) \quad \text{and} \quad t = t_0(\lambda).$$

We will describe the action of  $\mathbf{c} : \lambda \mapsto \widehat{\lambda}$  by first mapping  $(\alpha, \beta, \gamma)$  to a 5-tuple of partitions  $(\mu, \nu, \pi, \rho, \sigma)$ , and subsequently mapping that 5-tuple to different triple  $(\widehat{\alpha}, \widehat{\beta}, \widehat{\gamma})$  which goes to the right of, in the middle of, and below of the Durfee squares in  $\widehat{\lambda}$ .

1. First, let  $\mu = \beta$ .

Second, remove the following parts from  $\alpha$ :  $\alpha_{s-t-\beta_j+j}$  for  $1 \leq j \leq t$ . Let  $\nu$  be the partition comprising of parts removed from  $\alpha$ , and  $\pi$  be the partition comprised of the parts which were not removed.

Third, for  $1 \leq j \leq t$ , let

$$k_j = \max\{k \leq s - t \mid \gamma'_j - k \geq \pi_{s-t-k+1}\}.$$

Let  $\rho$  be the partition with parts  $\rho_j = k_j$  and  $\sigma$  be the partition with parts  $\sigma_j = \gamma'_j - k_j$ .

2. First, let  $\widehat{\gamma}' = \nu + \mu$ .

Second, let  $\widehat{\alpha} = \sigma \cup \pi$ .

Third, let  $\widehat{\beta} = \rho$ .

Figure 2-2 shows an example of  $\mathbf{c}$  and the relation between these two steps.

**Remark 2.2.1.** The key to understanding the map  $\mathbf{c}$  is the definition of  $k_j$ . By considering  $k = 0$ , we see that  $k_j$  is defined for all  $1 \leq j \leq t$ . Moreover, one can check that  $k_j$  is the *unique* integer  $k$  which satisfies

$$\pi_{s-t-k+1} \leq \gamma'_j - k \leq \pi_{s-t-k}. \quad (2.5)$$

(We assume  $\pi_0 = \infty$  and hence disregard the upper bound for  $s - t = k$ . This simply says that the first part of a partition does not have a part above it bounding it above in size.) This characterization of  $k_j$  can also be taken as its definition. Equation (2.5) is used repeatedly in our proof of the next lemma.

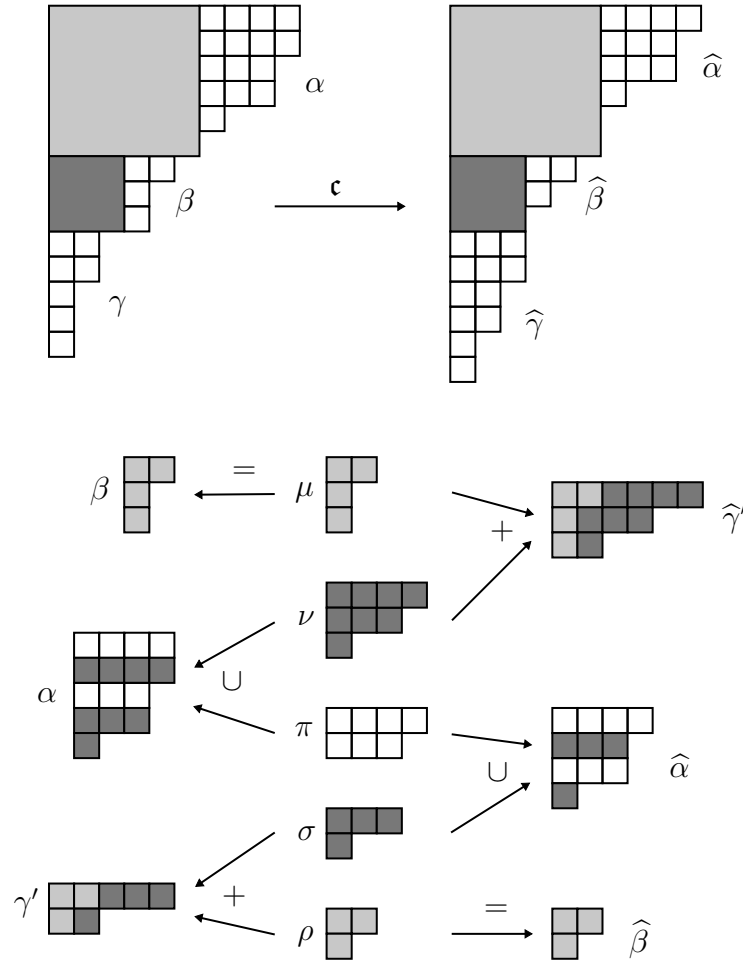

Figure 2-2: An example of the first symmetry involution  $\mathbf{c} : \lambda \mapsto \hat{\lambda}$ , where  $\lambda \in \mathcal{H}_{n,0,r}$  and  $\hat{\lambda} \in \mathcal{H}_{n,0,-r}$  for  $n = 71$ , and  $r = 1$ . The maps are defined by the following rules:  $\beta = \mu$ ,  $\alpha = \nu \cup \pi$ ,  $\gamma' = \sigma + \rho$ , while  $\hat{\beta} = \rho$ ,  $\hat{\alpha} = \pi \cup \sigma$ ,  $\hat{\gamma}' = \mu + \nu$ . Also,  $\lambda = (10, 10, 9, 9, 7, 6, 5, 4, 4, 2, 2, 1, 1, 1)$  and  $\hat{\lambda} = (10, 9, 9, 7, 6, 6, 5, 4, 3, 3, 3, 2, 2, 1, 1)$ .

**Lemma 2.2.2.** *The map  $\mathbf{c}$  defined above is an involution.*

*Proof.* Our proof is divided into five parts; we prove that

- (1)  $\rho$  is a partition,
- (2)  $\sigma$  is a partition,
- (3)  $\widehat{\lambda} = \mathbf{c}(\lambda)$  is a partition,
- (4)  $\mathbf{c}^2$  is the identity map, and
- (5)  $r_{2,0}(\widehat{\lambda}) = -r_{2,0}(\lambda)$ .

(1) Considering the bounds (2.5) for  $j$  and  $j + 1$ , note that if  $k_j \leq k_{j+1}$ , then

$$\pi_{s-t-k_{j+1}} + k_j \leq \pi_{s-t-k_{j+1}+1} + k_{j+1} \leq \gamma'_{j+1} \leq \gamma'_j \leq \pi_{s-t-k_j} + k_j.$$

This gives us

$$\pi_{s-t-k_{j+1}} \leq \gamma'_{j+1} - k_j \leq \pi_{s-t-k_j}$$

and uniqueness therefore implies that  $k_j = k_{j+1}$ . We conclude that  $k_j \geq k_{j+1}$  for all  $j$ , so  $\rho$  is a partition.

(2) If  $k_j > k_{j+1}$ , then we have  $s - t - k_j + 1 \leq s - t - k_{j+1}$  and therefore

$$\pi_{s-t-k_{j+1}} \leq \pi_{s-t-k_{j+1}}.$$

Again, by considering (2.5) for  $j$  and  $j + 1$ , we conclude that

$$\gamma'_j - k_j \geq \gamma'_{j+1} - k_{j+1}.$$

If  $k_j = k_{j+1}$ , then we simply need to recall that  $\gamma'$  is a partition to see that

$$\gamma'_j - k_j \geq \gamma'_{j+1} - k_{j+1}.$$

This implies that  $\sigma$  is a partition.

(3) By their definitions, it is clear that  $\mu$ ,  $\nu$ , and  $\pi$  are partitions. Since we just showed that  $\rho$  and  $\sigma$  are all partitions, it follows that  $\widehat{\alpha}$ ,  $\widehat{\beta}$ , and  $\widehat{\gamma}$  are also partitions. Moreover, by their definitions, we see that  $\mu$ ,  $\nu$ , and  $\sigma$  have at most  $t$  parts,  $\pi$  has at most  $s - t$  parts, and  $\rho$  has at most  $t$  parts each of which is less than or equal to  $s - t$ . This implies that  $\widehat{\alpha}$  has at most  $s$  parts,  $\widehat{\beta}$  has at most  $t$  parts each of which is less than or equal to  $s - t$ , and  $\widehat{\gamma}'$  has parts of size at most  $t$ . Therefore,  $\widehat{\alpha}$ ,  $\widehat{\beta}$ , and  $\widehat{\gamma}$  fit to the right of, in the middle of, and below Durfee squares of sizes  $s$  and  $t$  and so  $\mathbf{c}(\lambda)$  is a partition.

(4) We will apply  $\mathbf{c}$  twice to a Rogers-Ramanujan partition  $\lambda$  with  $\alpha$ ,  $\beta$ , and  $\gamma$  to the right of, in the middle of, and below its two Durfee squares. As usual, let  $\mu$ ,  $\nu$ ,  $\pi$ ,  $\rho$ ,  $\sigma$  be the partitions occurring in the intermediate stage of the first application of  $\mathbf{c}$  to  $\lambda$  and let  $\widehat{\alpha}$ ,  $\widehat{\beta}$ ,  $\widehat{\gamma}$  be the partitions to the right of, in the middle of, and below the Durfee squares of  $\widehat{\lambda} = \mathbf{c}(\lambda)$ . Similarly, let  $\widehat{\mu}$ ,  $\widehat{\nu}$ ,  $\widehat{\pi}$ ,  $\widehat{\rho}$ ,  $\widehat{\sigma}$  be the partitions occurring in the intermediate stage of the second application of  $\mathbf{c}$  and let  $\alpha^*$ ,  $\beta^*$ , and  $\gamma^*$  be

the partitions to the right of, in the middle of, and below the Durfee squares of  $\mathbf{c}^2(\lambda) = \mathbf{c}(\widehat{\lambda})$ .

First, note that  $\widehat{\mu} = \widehat{\beta} = \rho$ . Second, by (2.5) we have:

$$\pi_{s-t-k_j+1} \leq \gamma'_j - k_j = \sigma_j \leq \pi_{s-t-k_j}.$$

Since  $\sigma$  is a partition, this implies that  $\widehat{\alpha}_{s-t-k_j+j} = \sigma_j$ . On the other hand, since  $\widehat{\beta}_j = \rho_j = k_j$ , the map  $\mathbf{c}$  removes the rows  $\widehat{\alpha}_{s-t-k_j+j} = \sigma_j$  from  $\widehat{\alpha}$ . From here we conclude that  $\widehat{\nu} = \sigma$  and  $\widehat{\pi} = \pi$ . Third, define

$$\widehat{k}_j = \max\{\widehat{k} \leq s-t \mid \gamma'_j - \widehat{k} \geq \pi_{s-t-\widehat{k}+1}\}.$$

By Remark 2.2.1, we know that  $\widehat{k}_j$  as above is the unique integer  $\widehat{k}$  which satisfies:

$$\widehat{\pi}_{s-t-\widehat{k}+1} \leq \widehat{\gamma}'_j - \widehat{k} \leq \widehat{\pi}_{s-t-\widehat{k}}.$$

On the other hand, recall that  $\widehat{\gamma}'_j = \mu_j + \nu_j$  and  $\beta_j = \mu_j$ . This implies  $\widehat{\gamma}'_j - \beta_j = \nu_j$ . Also, by the definition of  $\nu$ , we have  $\nu_j = \alpha_{s-t-\beta_j+j}$ . Therefore, by the definition of  $\pi$ , we have:

$$\pi_{s-t-\beta_j+1} \leq \alpha_{s-t-\beta_j+j} = \nu_j = \widehat{\gamma}'_j - \beta_j \leq \pi_{s-t-\beta_j}.$$

Since  $\widehat{\pi} = \pi$ , by the uniqueness in Remark 2.2.1 we have  $\widehat{k}_j = \beta_j = \mu_j$ . This implies that  $\widehat{\rho} = \mu$  and  $\widehat{\sigma} = \nu$ .

Finally, the second step of our bijection gives  $\alpha^* = \nu \cup \pi = \alpha$ ,  $\beta^* = \mu = \beta$ , and  $(\gamma^*)' = \rho + \sigma = \gamma'$ . This implies that  $\mathbf{c}^2$  is the identity map.

(5) Using the results from (4), we have:

$$r_{2,0}(\lambda) = \beta_1 + \alpha_{s-t-\beta_1+1} - \gamma'_1 = \mu_1 + \nu_1 - \rho_1 - \sigma_1.$$

On the other hand,

$$r_{2,0}(\widehat{\lambda}) = \widehat{\beta}_1 + \widehat{\alpha}_{s-t-\widehat{\beta}_1+1} - \widehat{\gamma}'_1 = \rho_1 + \sigma_1 - \mu_1 - \nu_1.$$

We conclude that  $r_{2,0}(\widehat{\lambda}) = -r_{2,0}(\lambda)$ . □

### 2.2.3 Proof of the second symmetry

In order to prove the second symmetry we present a bijection

$$\mathfrak{d}_{m,r} : \mathcal{H}_{n,m,\leq -r} \rightarrow \mathcal{H}_{n-r-2m-2,m+2,\geq -r}.$$

This map will only be defined if  $r > 0$  or  $m = 0$ , in which case the first and second  $m$ -Durfee rectangles of a partition  $\lambda \in \mathcal{H}_{n,m,\leq -r}$  have non-zero width.

We describe the action of  $\mathfrak{d} := \mathfrak{d}_{m,r}$  by giving the sizes of the Durfee rectangles of  $\widehat{\lambda} := \mathfrak{d}_{m,r}(\lambda) = \mathfrak{d}(\lambda)$  and the partitions  $\widehat{\alpha}$ ,  $\widehat{\beta}$ , and  $\widehat{\gamma}$  which go to the right of, in the middle of, and below those Durfee rectangles in  $\widehat{\lambda}$ .

1. If  $\lambda$  has two  $m$ -Durfee rectangle of height

$$s := s_m(\lambda) \quad \text{and} \quad t := t_m(\lambda)$$

then  $\mu$  has two  $(m + 2)$ -Durfee rectangle of height

$$s' := s_{m+2}(\widehat{\lambda}) = s + 1 \quad \text{and} \quad t' := t_{m+2}(\widehat{\lambda}) = t + 1.$$

2. Let

$$k_1 = \max\{k \leq s - t \mid \gamma'_1 - r - k \geq \alpha_{s-t-k+1}\}.$$

Obtain  $\widehat{\alpha}$  from  $\alpha$  by adding a new part of size  $\gamma'_1 - r - k_1$ ,  $\widehat{\beta}$  from  $\beta$  by adding a new part of size  $k_1$ , and  $\widehat{\gamma}$  from  $\gamma$  by removing its first column.

Figure 2-2 shows an example of the bijection  $\mathfrak{d} = \mathfrak{d}_{m,r}$ .

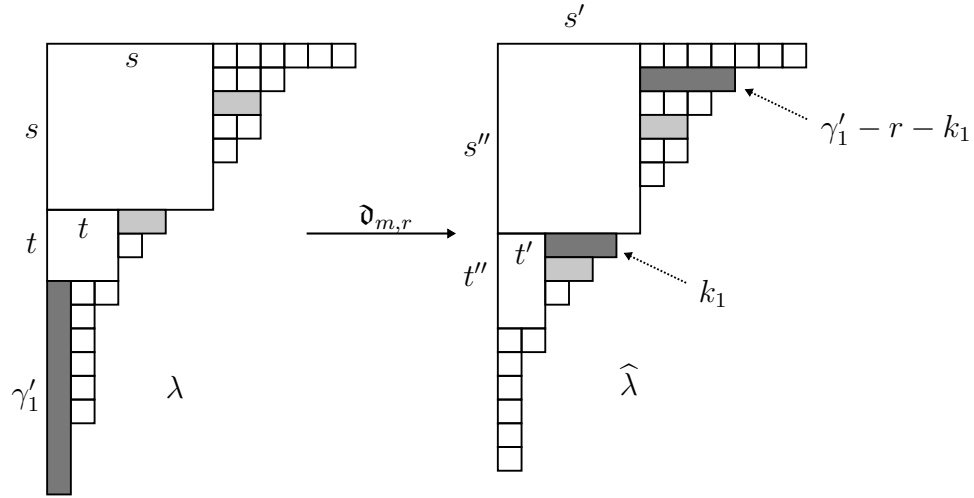

Figure 2-3: An example of the second symmetry bijection  $\mathfrak{d}_{m,r} : \lambda \mapsto \widehat{\lambda}$ , where  $\lambda \in \mathcal{H}_{n,m,\leq -r}$ ,  $\widehat{\lambda} \in \mathcal{H}_{n',m+2,\geq -r}$ , for  $m = 0$ ,  $r = 2$ ,  $n = 92$ , and  $n' = n - r - 2m - 2 = 88$ . Here  $r_{2,0}(\lambda) = 2 + 2 - 9 = -5 \leq -2$  and  $r_{2,2}(\widehat{\lambda}) = 3 + 4 - 6 = 1 \geq -2$ , where  $\lambda = (14, 10, 9, 9, 8, 7, 7, 5, 4, 3, 3, 2, 2, 2, 2, 2, 1, 1, 1)$  and  $\widehat{\lambda} = (13, 10, 9, 8, 8, 7, 6, 6, 5, 4, 3, 2, 2, 1, 1, 1, 1, 1)$ . Also,  $s = 7$ ,  $s' = s + 1 = 8$ ,  $s'' = s' - m - 2 = 6$ ,  $t = 3$ ,  $t' = 4$ ,  $t'' = 2$ ,  $\gamma'_1 = 9$ ,  $k_1 = 3$ , and  $\gamma'_1 - r - k_1 = 4$ .

**Remark 2.2.3.** As in Remark 2.2.1, by considering  $k = \beta_1$  we see that  $k_1$  is defined and indeed we have  $k_1 \geq \beta_1$ . Moreover, it follows from its definition that  $k_1$  is the *unique*  $k$  such that

$$\alpha_{s-t-k+1} \leq \gamma'_1 - r - k \leq \alpha_{s-t-k}. \quad (2.6)$$

(We assume  $\alpha_0 = \infty$  and hence disregard the upper bound for  $s - t = k$ . This simply says that the first part of a partition does not have a part above it bounding it above in size.)

**Lemma 2.2.4.** *The map  $\mathfrak{d} = \mathfrak{d}_{m,r}$  defined above is a bijection.*

*Proof.* Our proof has four parts:

- (1) we prove that  $\widehat{\lambda} = \mathfrak{d}(\lambda)$  is a partition,
- (2) we prove that the size of  $\widehat{\lambda} = \mathfrak{d}(\lambda)$  is  $n - r - 2m - 2$ ,
- (3) we prove that  $r_{2,m+2}(\widehat{\lambda}) \geq -r$ , and
- (4) we present the inverse map  $\mathfrak{d}^{-1}$ .

(1) To see that  $\widehat{\lambda}$  is a partition we simply have to note that since  $\lambda$  has  $m$ -Durfee rectangles of non-zero width,  $\widehat{\lambda}$  may have  $(m+2)$ -Durfee rectangles of width  $s-1$  and  $t-1$ . Also, the partitions  $\widehat{\alpha}$  and  $\widehat{\beta}$  have at most  $s+1$  and  $t+1$  parts, respectively, while the partitions  $\widehat{\beta}$  and  $\widehat{\gamma}$  have parts of size at most  $s-t$  and  $t-1$ , respectively. This means that they can sit to the right of, in the middle of, and below the two  $(m+2)$ -Durfee rectangles of  $\widehat{\lambda}$ .

(2) To prove that the above construction gives a partition  $\widehat{\lambda}$  of size  $n - r - 2m - 2$  note that the sum of the sizes of the rows added to  $\alpha$  and  $\beta$  is  $r$  less than the size of the column removed from  $\gamma$ , and that both the first and second  $(m+2)$ -Durfee rectangles of  $\widehat{\lambda}$  have size  $m+1$  less than the size of the corresponding  $m$ -Durfee rectangle of  $\lambda$ .

(3) By Remark 2.2.3, the part we inserted into  $\beta$  will be the largest part of the resulting partition, i.e.  $\widehat{\beta}_1 = k_1$ . By equation (2.6) we have:

$$\alpha_{s-t-k_1+1} \leq \gamma'_1 - r - k_1 \leq \alpha_{s-t-k_1}.$$

Therefore, we must have:

$$\widehat{\alpha}_{s'-t'-\widehat{\beta}_1+1} = \widehat{\alpha}_{s-t-k_1+1} = \gamma'_1 - r - k_1.$$

Indeed, we have chosen  $k_1$  in the *unique* way so that the rows we insert into  $\alpha$  and  $\beta$  are  $\widehat{\alpha}_{s'-t'-\widehat{\beta}_1+1}$  and  $\widehat{\beta}_1$  respectively.

The above two equations now allow us to bound the  $(2, m+2)$ -rank of  $\widehat{\lambda}$ :

$$\widehat{\alpha}_{s'-t'-\widehat{\beta}_1+1} + \widehat{\beta}_1 - (\ell(\widehat{\lambda}) - s' - t') = (\gamma'_1 - r - k_1) + k_1 - (\ell(\widehat{\lambda}) - s' - t') \geq -r,$$

where the last inequality follows from

$$\gamma'_1 \geq \gamma'_2 \geq \ell(\widehat{\lambda}) - s' - t'.$$

(4) The above characterization of  $k_1$  also shows us that to recover  $\alpha$ ,  $\beta$ , and  $\gamma$

from  $\widehat{\alpha}$ ,  $\widehat{\beta}$  and  $\widehat{\gamma}$ , we remove part  $\widehat{\alpha}_{s'-t'-\widehat{\beta}_1+1}$  from  $\widehat{\alpha}$ , remove part  $\widehat{\beta}_1$  from  $\widehat{\beta}$ , and add a column of height  $\widehat{\alpha}_{s'-t'-\widehat{\beta}_1+1} + \widehat{\beta}_1 + r$  to  $\widehat{\gamma}$ . Since we can also easily recover the sizes of the previous  $m$ -Durfee rectangles, we conclude that  $\mathfrak{d}$  is a bijection between the desired sets.  $\square$



# Chapter 3

## Generalized Rogers-Ramanujan identities: preliminaries and definitions

In the following chapters we will establish the following generalized Rogers-Ramanujan identities due to Andrews [And74], for  $k \geq 1$ :

$$\sum_{n_1=0}^{\infty} \cdots \sum_{n_{k-1}=0}^{\infty} \frac{q^{N_1^2 + N_2^2 + \cdots + N_{k-1}^2}}{(q)_{n_1} (q)_{n_2} \cdots (q)_{n_{k-1}}} = \prod_{\substack{n=1 \\ n \not\equiv 0, \pm k \pmod{2k+1}}}^{\infty} \frac{1}{1-q^n} \quad (3.1)$$

where  $N_j = n_j + n_{j+1} + \cdots + n_{k-1}$ .

The proof of these identities follows roughly the same steps as the proof of the first Rogers-Ramanujan identity presented in Chapter 2. First, by using the Jacobi triple product identity, we show that the generalized Rogers-Ramanujan identities above are equivalent to an identity of the same form as Schur's identity (2.2). Next, we introduce the notion of  $(k, m)$ -rank of a partition and using symmetries related to this new rank, we derive the generalizations of Schur's identity by simple algebraic manipulations. Bijective proofs of these symmetries appear in Chapter 4.

### 3.1 First step: Schur's identity

The first step of our proof of the generalized Rogers-Ramanujan identities is the application of the Jacobi triple product identity,

$$\sum_{k=-\infty}^{\infty} z^k t^{\frac{k(k+1)}{2}} = \prod_{i=1}^{\infty} (1 + zt^i) \prod_{j=0}^{\infty} (1 + z^{-1}t^j) \prod_{i=1}^{\infty} (1 - t^i),$$

to the right hand side of (3.1).

If we let  $t = q^{2k+1}$  and  $z = -q^{-k}$  we get:

$$\sum_{j=-\infty}^{\infty} (-1)^j q^{\frac{j(j+1)(2k+1)}{2} - kj} = \prod_{\substack{n=1 \\ n \equiv 0, \pm k \pmod{2k+1}}}^{\infty} (1 - q^n).$$

This gives us

$$\sum_{n_1=0}^{\infty} \cdots \sum_{n_{k-1}=0}^{\infty} \frac{q^{N_1^2 + N_2^2 + \cdots + N_{k-1}^2}}{(q)_{n_1} (q)_{n_2} \cdots (q)_{n_{k-1}}} = \frac{1}{(q)_{\infty}} \sum_{j=-\infty}^{\infty} (-1)^j q^{\frac{j(j+1)(2k+1)}{2} - kj}, \quad (3.2)$$

with  $N_j = n_j + n_{j+1} + \cdots + n_{k-1}$ , which we will refer to as the generalized Schur identities. We have chosen this name because the first step of Schur's combinatorial proof of the Rogers-Ramanujan identities [Sch17] was also the application of the Jacobi triple product identity in this manner and gave the case  $k = 2$ . This step has since become classical and is used in many Rogers-Ramanujan proofs.

We note that the Jacobi triple product identity has a combinatorial proof due to Sylvester (see [Pak05, Wri65]) and so its application does not change the combinatorial nature of our proof.

## 3.2 Successive Durfee rectangles

Andrews introduced the idea of successive Durfee squares to study his generalized Rogers-Ramanujan identities [And79]. He interpreted the left hand sides of equations (3.1) and (3.2) as follows:

**Definition 3.2.1.** *The first Durfee square of a partition  $\lambda$  is the largest square that fits in the upper left hand corner of the diagram of  $\lambda$ . The second Durfee square is the largest square that fit in the diagram of  $\lambda$  below the first Durfee square of  $\lambda$ . In general, the  $k$ th Durfee square is the largest square that fits below the  $(k - 1)$ st Durfee square of  $\lambda$ .*

See Figure 3-1 for an example.

Let  $q_{k-1}(n)$  denoted the number of partitions with at most  $k - 1$  Durfee squares. Now the generating function for partitions with Durfee squares of size  $N_1, N_2, \dots, N_{k-1}$  and no part below the  $k - 1$ st Durfee square is

$$\frac{q^{N_1^2 + N_2^2 + \cdots + N_{k-1}^2}}{(q)_{n_1} (q)_{n_2} \cdots (q)_{n_{k-1}}}$$

where  $n_j = N_j - N_{j+1}$  so that  $N_j = n_j + n_{j+1} + \cdots + n_{k-1}$ . This can be seen by a simple

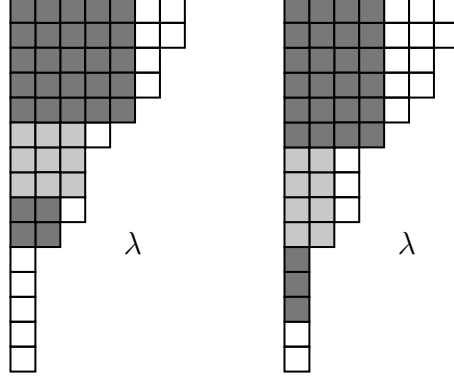

Figure 3-1: The first three successive Durfee squares and 1-Durfee rectangles of  $\lambda = (7, 7, 6, 6, 5, 4, 3, 3, 3, 2, 1, 1, 1, 1, 1)$ . On the left we see that  $\lambda$  has successive Durfee squares of size 5, 3, and 2. On the right we see that  $\lambda$  has successive 1-Durfee rectangles of width 4, 2, and 1.

counting argument as is done by Andrews [And79]. Alternatively, in Appendix A we show this bijectively using a map defined in Chapter 4.

Therefore the generating function of partitions with at most  $k - 1$  Durfee squares is

$$1 + \sum_{n=1}^{\infty} q_{k-1}(n) q^n = \sum_{n_1=0}^{\infty} \cdots \sum_{n_{k-1}=0}^{\infty} \frac{q^{N_1^2 + N_2^2 + \cdots + N_{k-1}^2}}{(q)_{n_1} (q)_{n_2} \cdots (q)_{n_{k-1}}}$$

with  $N_j = n_j + n_{j+1} + \cdots + n_{k-1}$  which is indeed the left hand side of (3.1).

Since the right hand side of the generalized Rogers-Ramanujan identities (3.1) can be interpreted as enumerating partitions into parts not congruent to  $0, \pm k \pmod{2k+1}$ , this identity is equivalent to the following theorem.

**Theorem 3.2.2** (Andrews, [And79]). *The number of partitions of  $n$  with at most  $k - 1$  successive Durfee squares equals the number of partitions of  $n$  into parts not congruent to  $0, \pm k \pmod{2k+1}$ .*

Of course, the generalized Schur identities also have the following interpretation using Andrews' successive Durfee squares:

**Theorem 3.2.3.** *The number of partitions of  $n$  with at most  $k - 1$  successive Durfee squares is*

$$\sum_{j=-\infty}^{\infty} (-1)^j p\left(n - \left(\frac{j(j+1)(2k+1)}{2} - kj\right)\right).$$

Recall that  $p(n)$  is the number of partitions of  $n$  and therefore, when  $n < 0$ ,  $p(n) = 0$  which makes this a finite sum.

In order to prove the generalized Schur identities, we extend the notion of successive Durfee squares.

**Definition 3.2.4.** *For any integer  $m$ , define an  $m$ -rectangle to be a rectangle whose height exceeds its width by exactly  $m$ . We require  $m$ -rectangles to have non-zero height though they may have width zero.*

In particular, notice that 0-rectangles are simply squares. The technical detail about non-zero height will be needed to obtain Observation 3.4.2.

We define successive  $m$ -Durfee rectangles in the same manner as Andrews' successive Durfee squares.

**Definition 3.2.5.** *The first  $m$ -Durfee rectangle of a partition  $\lambda$  is the largest  $m$ -rectangle that fits in the upper left hand corner of the diagram of  $\lambda$ . The second  $m$ -Durfee rectangle is the largest  $m$ -rectangle that fits in the diagram of  $\lambda$  below the first Durfee square of  $\lambda$ . In general, the  $k$ th successive  $m$ -Durfee rectangle is the largest  $m$ -rectangle that fits below the  $(k - 1)$ st Durfee square of  $\lambda$ .*

Again, see Figure 3-1.

Note that the possibility of width zero  $m$ -rectangles means that, for  $m > 0$ , all partitions (including the empty partition) have arbitrarily many successive  $m$ -Durfee rectangles.

### 3.3 Definition of $(k, m)$ -rank

In Chapter 2, we introduced the notion of  $(2, m)$ -rank for partitions with at least two successive  $m$ -Durfee rectangles. Here we present the more general notion of  $(k, m)$ -rank for partitions with at least  $k$  successive  $m$ -Durfee rectangles.

First, given a partition  $\lambda$  with  $k$  successive  $m$ -Durfee rectangles, denote by  $\lambda^i$  the partition to the right of the  $i$ th  $m$ -Durfee rectangle and denote by  $\alpha$  the partition below the  $k$ th  $m$ -Durfee rectangle. Moreover, let  $N_1, N_2, \dots, N_k$  denote the widths of the first  $k$  successive  $m$ -Durfee rectangles. Note that, for all  $i$ ,  $\lambda^i$  has at most  $N_i + m$  parts and, for  $i \geq 2$ , the largest part of  $\lambda^i$  is at most  $N_{i-1} - N_i$ . See Figure 3-2.

To define rank, we want to select one part from each of the partitions  $\lambda^1, \lambda^2, \dots, \lambda^k$ . These parts will be selected recursively starting from the partition  $\lambda^k$  and moving up to  $\lambda^1$ .

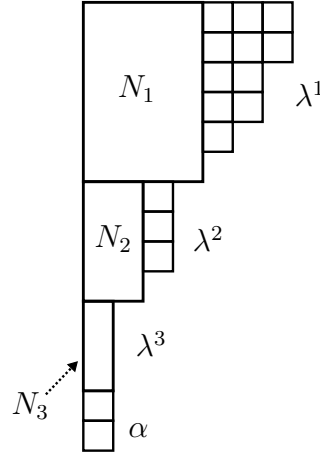

Figure 3-2: Successive Durfee rectangles of width  $N_1$ ,  $N_2$ , and  $N_3$  and names for the partitions to the right,  $\lambda^1$ ,  $\lambda^2$ , and  $\lambda^3$ , and below,  $\alpha$ , those Durfee rectangles.

### Selection of parts from $\lambda$

Let  $\lambda^1, \lambda^2, \dots, \lambda^k$  be the partitions to the right of the first  $k$  successive  $m$ -Durfee rectangles of  $\lambda$ .

- Select the first (that is, largest) part from  $\lambda^k$ .
- Suppose you have selected the  $j$ th part  $\lambda_j^i$  from  $\lambda^i$ .  
Let  $d = (N_{i-1} - N_i) - \lambda_j^i$ . This is the difference between the maximal possible size of a part of  $\lambda^i$  and the selected part of  $\lambda^i$ .  
Select the  $(j + d)$ th part of  $\lambda^{i-1}$ .

See Figure 3-3 for two examples of this selection process. On the left hand side, we consider  $\lambda$  with 3 successive Durfee squares. First we select the first part of  $\lambda^3$ . Next we calculate  $d = (3 - 2) - 1 = 0$  and select the  $1 + 0 = 1$ st part of  $\lambda^2$ . Finally we calculate  $d = (5 - 3) - 1 = 1$  and select the  $1 + 1 = 2$ nd part of  $\lambda^1$ .

For this selection procedure to be well-defined, it suffices to show that the following lemma holds.

**Lemma 3.3.1.** *If the  $j$ th part of  $\lambda^i$  has been selected, then  $j \leq N_i + m$ .*

This lemma says that the selected part of the partition  $\lambda^i$  is never below the bottom row of the  $m$ -Durfee rectangle sitting to its left.

*Proof.* We will prove the stronger statement that if the  $j$ th part of  $\lambda^i$  has been selected then  $j \leq 1 + N_i - N_k$ .

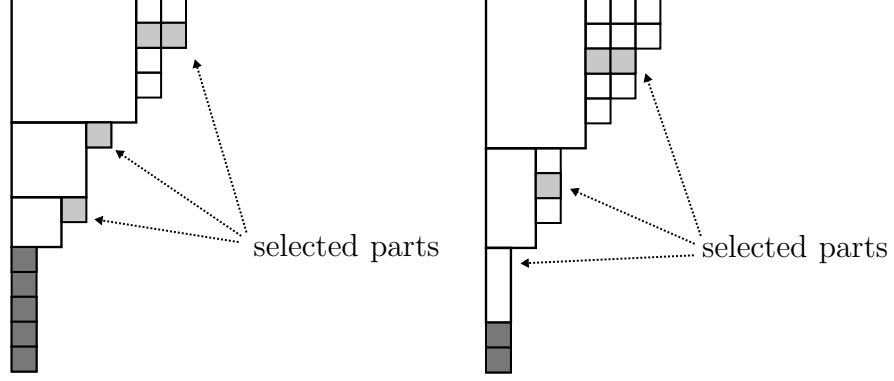

Figure 3-3: For partition  $\lambda = (7, 7, 6, 6, 5, 4, 3, 3, 3, 2, 1, 1, 1, 1, 1)$ , we have  $a_{3,0}(\lambda) = 2 + 1 + 1 = 4$ ,  $b_{3,0}(\lambda) = 5$ , and  $r_{3,0}(\lambda) = 4 - 5 = -1$ , while  $a_{3,1}(\lambda) = 2 + 1 + 0 = 3$ ,  $b_{3,1}(\lambda) = 2$ , and  $r_{3,1}(\lambda) = 3 - 2 = 1$ .

If  $m \leq 0$ , the  $k$ th successive  $m$ -Durfee square has non-zero height, and so its width is  $N_k \geq 1 + m$ , which gives us

$$1 + N_i - N_k \leq N_i + m.$$

If  $m > 0$ , we get  $N_k \geq 0$  so

$$1 + N_i - N_k \leq N_i + 1 \leq N_i + m.$$

Therefore the statement in the lemma follows from  $j \leq 1 + N_i - N_k$ .

To show that  $j \leq 1 + N_i - N_k$ , we proceed by induction, starting with  $\lambda^k$  and moving up to  $\lambda^1$ .

Since we select the first part of  $\lambda^k$  and the height of an  $m$ -Durfee rectangle is always non-zero, we have  $1 \leq N_k + m$ .

If the  $j$ th part of  $\lambda^i$  has been selected, we select the  $(j + d) = (j + (N_{i-1} - N_i) - \lambda_j^i)$ th part of  $\lambda^{i-1}$ . Now our inductive hypothesis says that then  $j \leq 1 + N_i - N_k$ . Hence we see that

$$\begin{aligned} j + (N_{i-1} - N_i) - \lambda_j^i &\leq 1 + N_i - N_k + N_{i-1} - N_i - \lambda_j^i \\ &\leq 1 + N_{i-1} - N_k \end{aligned}$$

as desired. □

Finally, we can give the definition of  $(k, m)$ -rank,  $r_{k,m}(\lambda)$ .

**Definition 3.3.2.** For  $k > 0$ , let

- $a_{k,m}(\lambda)$  be the sum of the parts selected from  $\lambda^1, \lambda^2, \dots, \lambda^k$ ,

- $b_{k,m}(\lambda) = \ell(\alpha)$ , and
- $r_{k,m}(\lambda) = a_{k,m}(\lambda) - b_{k,m}(\lambda)$ .

See Figure 3-3 for examples.

### 3.4 Symmetries

Let  $h(n, k, m, r)$  be the number of partitions of  $n$  with  $(k, m)$ -rank equal to  $r$ . Similarly, let  $h(n, k, m, \leq r)$  be the number of partitions of  $n$  with  $(k, m)$ -rank less than or equal to  $r$  and let  $h(n, k, m, \geq r)$  be the number of partitions of  $n$  with  $(k, m)$ -rank greater than or equal to  $r$ .

As was the case for  $(2, m)$ -rank, we can establish relationships between these numbers by combinatorial means. In the following section these relationships will be used to establish the generalized Schur identities by simple algebraic manipulation.

Recall that  $q_{k-1}(n)$  denotes the number of partitions with at most  $k-1$  Durfee squares, so that  $p(n) - q_{k-1}(n)$  is the number of partitions with at least  $k$  Durfee squares.

The following two observations follow directly from our definitions since  $(k, 0)$ -rank is only defined for the set of partitions with  $k$  non-empty Durfee squares, whereas  $(k, m)$ -rank is defined for the set of all partitions when  $m > 0$ .

**Observation 3.4.1** (First observation). *For  $m = 0$ ,*

$$h(n, k, 0, \leq r) + h(n, k, 0, \geq r + 1) = p(n) - q_{k-1}(n).$$

**Observation 3.4.2** (Second observation). *For  $m > 0$ ,*

$$h(n, k, m, \leq r) + h(n, k, m, \geq r + 1) = p(n).$$

There are also more complicated relations between these numbers. Here we will give only the version needed to complete the proof of the generalized Schur identities. General versions of these symmetries will be given in the next chapter.

**Corollary 3.4.3** (First symmetry). *For  $r \in \mathbb{Z}$  and  $m = 0$ ,*

$$h(n, k, 0, r) = h(n, k, 0, -r).$$

*Proof.* Follows from Theorem 4.2.1. □

**Corollary 3.4.4** (Second symmetry). *For  $m, r \in \mathbb{Z}$ , if  $r > 0$  or if  $m = r = 0$ ,*

$$h(n, k, m, \leq -r) = h(n - r - k(m + 1), k, m + 2, \geq -r).$$

*Proof.* Follows from Theorem 4.3.1. □

### 3.5 Algebraic derivation of Schur's identity

We can now complete the proof of the generalized Schur identities. We proceed in a fashion similar to the case  $k = 2$  in the previous chapter.

For every  $j \geq 0$  let

$$a_j = h\left(n - jr - \frac{j(j-1)}{2} - k(jm + j^2), k, m + 2j, \leq -r - j\right),$$

$$b_j = h\left(n - jr - \frac{j(j-1)}{2} - k(jm + j^2), k, m + 2j, \geq -r - j + 1\right).$$

In this notation, the second observation, 3.4.2, gives us

$$a_j + b_j = p\left(n - jr - \frac{j(j-1)}{2} - k(jm + j^2)\right),$$

for all  $j > 0$ . For  $j, r > 0$ , the second symmetry, 3.4.4, gives us

$$a_j = b_{j+1}.$$

Applying these multiple times we get (for  $r > 0$  and for  $m = r = 0$ ):

$$\begin{aligned} h(n, k, m, \leq -r) &= a_0 = b_1 \\ &= b_1 + (a_1 - b_2) - (a_2 - b_3) + (a_3 - b_4) - \dots \\ &= (b_1 + a_1) - (b_2 + a_2) + (b_3 + a_3) - (b_4 + a_4) + \dots \\ &= \sum_{j=1}^{\infty} (-1)^{j-1} p\left(n - jr - \frac{j(j-1)}{2} - k(jm + j^2)\right). \end{aligned}$$

In terms of the generating functions

$$H_{k,m,\leq r}(q) := \sum_{n=0}^{\infty} h(n, k, m, \leq r) q^n, \text{ and}$$

$$H_{k,m,\geq r}(q) := \sum_{n=0}^{\infty} h(n, k, m, \geq r) q^n,$$

this gives (for  $r > 0$  and for  $m = r = 0$ )

$$H_{k,m,\leq r}(q) = \frac{1}{(q)_{\infty}} \sum_{j=1}^{\infty} (-1)^{j-1} q^{jr + \frac{j(j-1)}{2} + k(jm + j^2)}. \quad (3.3)$$

In particular, we have:

$$H_{k,0,\leq 0}(q) = \frac{1}{(q)_\infty} \sum_{j=1}^{\infty} (-1)^{j-1} q^{\frac{j(j-1)}{2} + kj^2}, \text{ and}$$

$$H_{k,0,\leq -1}(q) = \frac{1}{(q)_\infty} \sum_{j=1}^{\infty} (-1)^{j-1} q^{\frac{j(j+1)}{2} + kj^2}.$$

From the first symmetry 3.4.3 and the first observation 3.4.1 we note that

$$H_{k,0,\leq 0}(q) + H_{k,0,\leq -1}(q) = H_{k,0,\leq 0}(q) + H_{k,0,\geq 1}(q)$$

is the generating function for partitions with at least  $k$  successive Durfee squares. We conclude:

$$\begin{aligned} & \frac{1}{(q)_\infty} \sum_{j=1}^{\infty} (-1)^{j-1} q^{\frac{j(j-1)}{2} + kj^2} + \frac{1}{(q)_\infty} \sum_{j=1}^{\infty} (-1)^{j-1} q^{\frac{j(j+1)}{2} + kj^2} \\ &= \frac{1}{(q)_\infty} - \sum_{n_1=0}^{\infty} \cdots \sum_{n_{k-1}=0}^{\infty} \frac{q^{N_1^2 + N_2^2 + \cdots + N_{k-1}^2}}{(q)_{n_1} (q)_{n_2} \cdots (q)_{n_{k-1}}} \end{aligned}$$

which implies the generalized Schur identities and completes the proof of the generalized Rogers-Ramanujan identities.



# Chapter 4

## Symmetries for $(k, m)$ -rank

The heart of this new proof is the combinatorial proof of the first and second symmetries. We will prove both by direct bijections between the set of partitions counted on both sides. Our bijections are based on an insertion procedure which is closely related to the procedure used to select parts in the definition of  $(k, m)$ -rank in the previous chapter.

### 4.1 Selection and insertion

First, we generalize the selection procedure found in the previous chapter.

#### Selection of parts from a sequence of partitions $\lambda^1, \lambda^2, \dots, \lambda^k$

Given a sequence of  $k$  partitions,

$$\lambda^1, \lambda^2, \dots, \lambda^k,$$

and  $k - 1$  nonnegative integers,

$$p_2, p_3, \dots, p_k,$$

such that

$$f(\lambda^2) \leq p_2, f(\lambda^3) \leq p_3, \dots, f(\lambda^k) \leq p_k,$$

we select one row from each partition as follows:

- Select the first (that is, the largest) part of  $\lambda^k$ .
- Suppose we have selected the  $j$ th part,  $\lambda^i_j$ , of  $\lambda^i$ , then select the  $(j + p_i - \lambda^i_j)$ th part of  $\lambda^{i-1}$ .

**Definition 4.1.1.** Let  $A(\lambda^1, \lambda^2, \dots, \lambda^k; p_2, p_3, \dots, p_k)$  be the sum of the selected parts.

When  $p_2, p_3, \dots, p_k$  are clear from the context, we will write  $A(\lambda^1, \lambda^2, \dots, \lambda^k)$ .

See Figure 4-1 for examples of this selection procedure. On the left hand side we select the first part of  $\lambda^4$ . Then we select the  $1 + (3 - 2) = 2$ nd part from  $\lambda^3$ , the  $2 + (2 - 2) = 2$ nd part from  $\lambda^2$ , and the  $2 + (4 - 2) = 4$ th part from  $\lambda^1$ . This gives  $A(\lambda^1, \lambda^2, \lambda^3, \lambda^4) = 1 + 2 + 2 + 2 = 7$ .

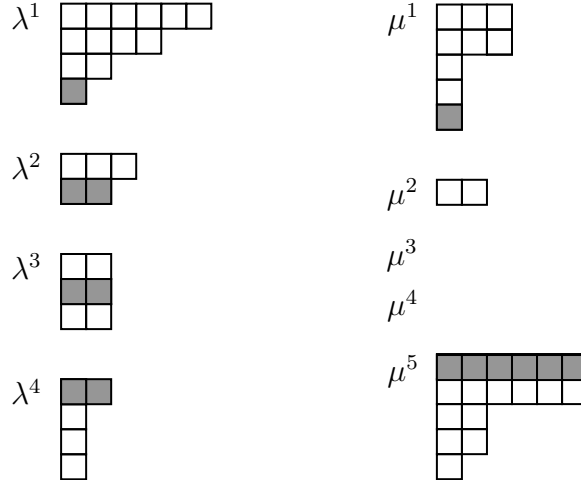

Figure 4-1: Selection of rows from  $\lambda^1, \lambda^2, \lambda^3$ , and  $\lambda^4$  with  $p_2 = 4, p_3 = 2$ , and  $p_4 = 3$  to get  $A(\lambda^1, \lambda^2, \lambda^3, \lambda^4) = 7$ . Selection of rows from  $\mu^1, \mu^2, \mu^3, \mu^4$ , and  $\mu^5$  with  $p_2 = 2, p_3 = 0, p_4 = 2$ , and  $p_5 = 6$  to get  $A(\mu^1, \mu^2, \mu^3, \mu^4, \mu^5) = 7$ . Selected parts are shown in grey.

Notice that this procedure resembles the procedure used in the previous chapter to define  $a_{k,m}(\lambda)$ . In fact, given a partition  $\lambda$  with  $k$  successive  $m$ -Durfee rectangles of widths  $N_1, N_2, \dots, N_k$ , let  $\lambda^1, \lambda^2, \dots, \lambda^k$  be the partitions to the right of the first  $k$   $m$ -Durfee rectangles. Then we have

$$f(\lambda^2) \leq N_1 - N_2, f(\lambda^3) \leq N_2 - N_3, \dots, f(\lambda^k) \leq N_{k-1} - N_k$$

and, by definition,

$$a_{k,m}(\lambda) = A(\lambda^1, \lambda^2, \dots, \lambda^k; N_1 - N_2, N_2 - N_3, \dots, N_{k-1} - N_k).$$

Based on this definition of selection from a sequence of partitions, we can define an insertion algorithm on which our two symmetries are based. The following proposition describes the result of insertion.

**Proposition 4.1.2.** *Given a sequence of  $k$  partitions*

$$\lambda^1, \lambda^2, \dots, \lambda^k$$

*with  $|\lambda^1| + |\lambda^2| + \dots + |\lambda^k| = n$ ,*

$k - 1$  nonnegative integers

$$p_2, p_3, \dots, p_k$$

such that

$$f(\lambda^2) \leq p_2, f(\lambda^3) \leq p_3, \dots, f(\lambda^k) \leq p_k,$$

and an integer  $a \geq A(\lambda^1, \lambda^2, \dots, \lambda^k; p_2, p_3, \dots, p_k)$ ,

there exists a unique sequence of  $k$  partitions,

$$\mu^1, \mu^2, \dots, \mu^k,$$

obtained by inserting one (possibly empty) part to each of the original partitions,

$$\lambda^1, \lambda^2, \dots, \lambda^k,$$

such that

1.  $|\mu^1| + |\mu^2| + \dots + |\mu^k| = n + a$ ,
2.  $f(\mu^2) \leq p_2, f(\mu^3) \leq p_3, \dots, f(\mu^k) \leq p_k$ ,
3.  $A(\mu^1, \mu^2, \dots, \mu^k; p_2, p_3, \dots, p_k) = a$ .

Moreover, the inserted parts have the same length as those which are selected when calculating  $A(\mu^1, \mu^2, \dots, \mu^k; p_2, p_3, \dots, p_k)$ .

We will prove this lemma by induction on  $a$ . The two following lemmas are the required base case and inductive step.

**Lemma 4.1.3.** *Proposition 4.1.2 (without uniqueness) is true for*

$$a = A(\lambda^1, \lambda^2, \dots, \lambda^k; p_2, p_3, \dots, p_k).$$

*Proof.* For each  $\lambda^i$ , consider the size of the part selected from that partition. Insert an additional part in  $\lambda^i$  of the same size as the selected part to obtain  $\mu^i$ . See Figure 4-2.

We have inserted parts totaling  $a = A(\lambda^1, \lambda^2, \dots, \lambda^k; p_2, p_3, \dots, p_k)$  since the sum of the selected parts of  $\lambda^1, \lambda^2, \dots, \lambda^k$  is  $a$ . This implies condition (1).

Note that, for each  $\lambda^i$ , since we are inserting a part of the same size as the selected part, it can be inserted directly above the selected row in  $\lambda^i$ . Again since we are inserting parts of the same size and  $p_2, p_3, \dots, p_k$  remain constant, when we select rows from  $\mu^1, \mu^2, \dots, \mu^k$ , we will select the rows we have just added. Moreover, this gives  $A(\mu^1, \mu^2, \dots, \mu^k; p_2, p_3, \dots, p_k) = a$ , condition (3).

Finally, condition (2) is satisfied since  $f(\lambda^i) \leq p_i$  and the part selected from  $\lambda^i$  is at most  $f(\lambda^i)$ .  $\square$

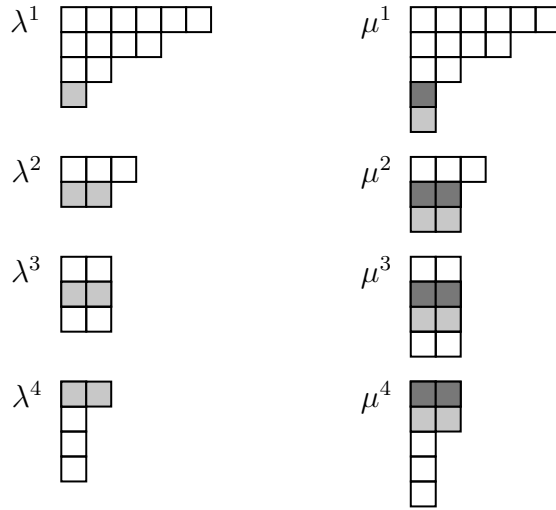

Figure 4-2: Inserting  $7 = A(\lambda^1, \lambda^2, \lambda^3, \lambda^4)$  into  $\lambda^1, \lambda^2, \lambda^3,$  and  $\lambda^4$  gives  $\mu^1, \mu^2, \mu^3,$  and  $\mu^4$ .

**Lemma 4.1.4.** *If Proposition 4.1.2 (without uniqueness) is true for  $a = b$ , then it is true for  $a = b + 1$ .*

*Proof.* Suppose  $\nu^1, \nu^2, \dots, \nu^k$  are the partitions obtained by inserting  $b$  into  $\lambda^1, \lambda^2, \dots, \lambda^k$  as in Proposition 4.1.2. To insert  $b + 1$  into  $\lambda^1, \lambda^2, \dots, \lambda^k$  we need to determine which partition  $\lambda^i$  gets a part that is larger than it did when we inserted  $b$  into  $\lambda^1, \lambda^2, \dots, \lambda^k$ .

If the selected part of each of  $\nu^1, \nu^2, \dots, \nu^k$  is the first part of that partition, then we let  $\mu^2 = \nu^2, \mu^3 = \nu^3, \dots, \mu^k = \nu^k$  and we let  $\mu^1$  be  $\nu^1$  except with first part one larger, i.e.  $\mu^1 = \nu^1 + (1)$ . See Figure 4-3.

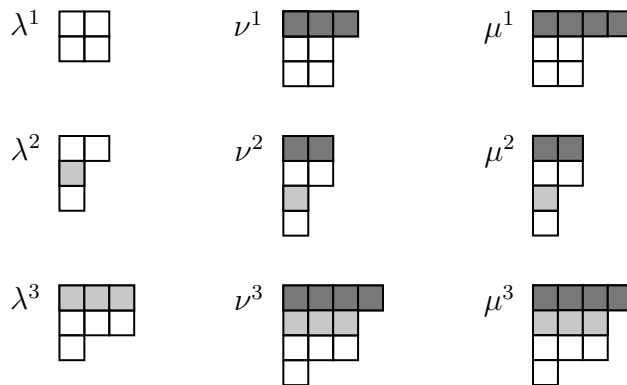

Figure 4-3: Consider  $\lambda^1, \lambda^2,$  and  $\lambda^3$  with  $p_2 = 4$  and  $p_3 = 2$  so that  $A(\lambda^1, \lambda^2, \lambda^3) = 4$ . If  $\nu^1, \nu^2,$  and  $\nu^3$  are obtained by inserting 9 into  $\lambda^1, \lambda^2,$  and  $\lambda^3$ , then  $\mu^1, \mu^2,$  and  $\mu^3$  are obtained by inserting 10 into  $\lambda^1, \lambda^2,$  and  $\lambda^3$ .

Otherwise consider the smallest  $i$  such that the selected part of  $\nu^i$  is *not* equal to the part above it or  $p_i$  if it is the first part of  $\nu^i$ . Add 1 to this part in  $\nu^i$  to obtain  $\mu^i$ . The rest are defined by  $\mu^j = \nu^j$ . See Figures 4-4 and 4-5.

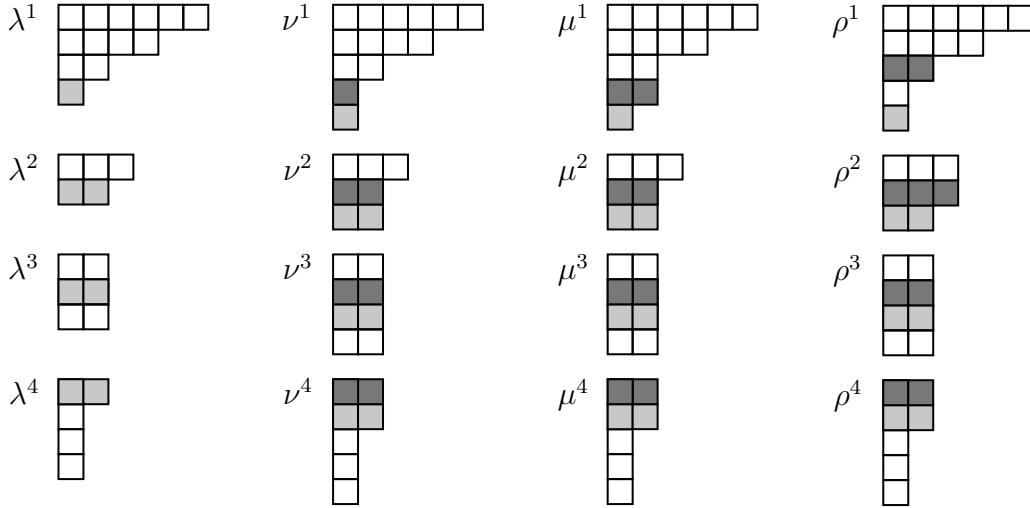

Figure 4-4: Consider  $\lambda^1, \lambda^2, \lambda^3,$  and  $\lambda^4$  with  $p_2 = 4, p_3 = 2,$  and  $p_4 = 3$ . We insert 7 into  $\lambda^1, \lambda^2, \lambda^3,$  and  $\lambda^4$  to get  $\nu^1, \nu^2, \nu^3,$  and  $\nu^4$ , 8 to get  $\mu^1, \mu^2, \mu^3,$  and  $\mu^4$ , and 9 to get  $\rho^1, \rho^2, \rho^3,$  and  $\rho^4$ .

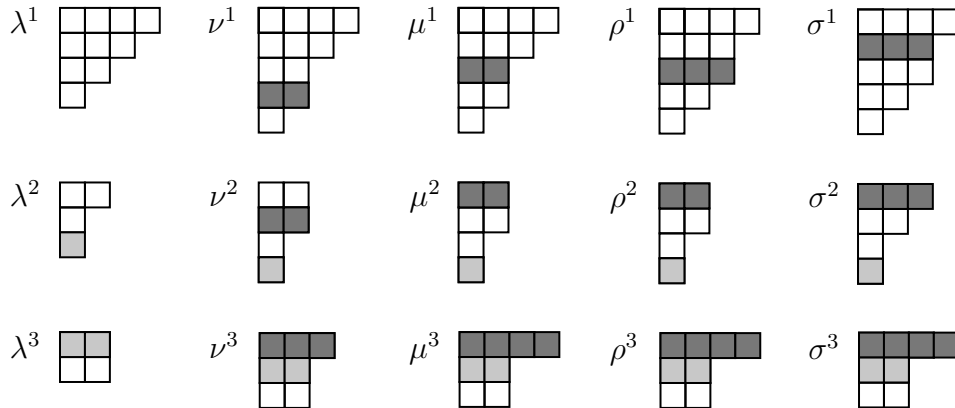

Figure 4-5: Consider  $\lambda^1, \lambda^2,$  and  $\lambda^3$  with  $p_2 = 4$  and  $p_3 = 4$ . We insert 5 into  $\lambda^1, \lambda^2,$  and  $\lambda^3$  to get  $\nu^1, \nu^2,$  and  $\nu^3$ , 6 to get  $\mu^1, \mu^2,$  and  $\mu^3$ , 7 to get  $\rho^1, \rho^2,$  and  $\rho^3$ , and 8 to get  $\sigma^1, \sigma^2,$  and  $\sigma^3$ .

Condition (1) follows immediately from either case since we have only added 1 to one part. Also note that we never add 1 to a row that already has length  $p_i$  which implies condition (2).

Now, consider the selected part of  $\mu^1, \mu^2, \dots, \mu^k$ . Let  $i$  be as found above. For partitions  $\mu^{i+1}, \dots, \mu^k$  we select the same part as in  $\nu^{i+1}, \dots, \nu^k$ . In  $\mu^i$  we select the part to which we added 1. For partitions  $\mu^1, \dots, \mu^{i-1}$  we select the part directly above the selected part of  $\nu^1, \dots, \nu^{i-1}$  but because of our choice of  $i$  these selected parts are equal to the selected parts of  $\nu^1, \dots, \nu^{i-1}$ . Therefore  $A(\nu^1, \nu^2, \dots, \nu^k) = A(\mu^1, \mu^2, \dots, \mu^k) + 1$ , implying condition (3).  $\square$

*Proof of Proposition 4.1.2.* To complete the proof of Proposition 4.1.2, we simply need to check uniqueness.

Suppose  $\mu^1, \mu^2, \dots, \mu^k$  and  $\nu^1, \nu^2, \dots, \nu^k$  are both sequences satisfying the theorem for some particular sequence  $\lambda^1, \lambda^2, \dots, \lambda^k$  and integer  $a \geq A(\lambda^1, \lambda^2, \dots, \lambda^k)$ .

Since removing the selected parts of each sequence gives  $\lambda^1, \lambda^2, \dots, \lambda^k$ , the sequences  $\mu^1, \mu^2, \dots, \mu^k$  and  $\nu^1, \nu^2, \dots, \nu^k$  must differ in a selected part. Let  $i$  be the largest index so that the selected part of  $\mu^i$  and  $\nu^i$  are not equal. Since  $i$  is the largest index where this happens, the selected parts of  $\mu^i$  and  $\nu^i$  must sit in the same row, say  $j$ . Without loss of generality,  $\mu^i_j > \nu^i_j$ .

Our selection procedure now forces the selected part of  $\mu^s$  to be greater than or equal to the selected part of  $\nu^s$  for  $s < i$ , which gives us

$$A(\mu^1, \mu^2, \dots, \mu^k) > A(\nu^1, \nu^2, \dots, \nu^k).$$

However, both of these are equal to  $a$  and so we have reached a contradiction. There cannot be a difference between the sequence  $\mu^1, \mu^2, \dots, \mu^k$  and the sequence  $\nu^1, \nu^2, \dots, \nu^k$ .  $\square$

Note that together, the two lemmas give an effective recursive algorithm for finding  $\mu^1, \mu^2, \dots, \mu^k$ .

This lemma will be used repeatedly to establish the bijections proving the first and second symmetries. For convenience, we will use the following notation. Let

$$\phi_{\{p_2, \dots, p_k\}}(a; \lambda^1, \lambda^2, \dots, \lambda^k) = (\mu^1, \mu^2, \dots, \mu^k)$$

where  $\mu^1, \mu^2, \dots, \mu^k$  are the partitions uniquely defined by Proposition 4.1.2. When  $p_2, \dots, p_k$  are clearly given by the context we will also write

$$\phi_{\{p_2, \dots, p_k\}}(a; \lambda^1, \lambda^2, \dots, \lambda^k) = \phi(a; \lambda^1, \lambda^2, \dots, \lambda^k).$$

Of course,  $\phi$  is only defined for  $\lambda^1, \lambda^2, \dots, \lambda^k$  and  $a$  such that  $A(\lambda^1, \lambda^2, \dots, \lambda^k) \leq a$ .

Equivalently, the proof of Proposition 4.1.2 tells us that we can describe  $\phi$  as follows:

**Description of  $\phi$ : Insertion**

Let  $\lambda^1, \lambda^2, \dots, \lambda^k$  and  $a$  be such that  $A(\lambda^1, \lambda^2, \dots, \lambda^k) \leq a$ .

First insert a part of the same length as the part selected from  $\lambda^i$  when calculating  $A(\lambda^1, \lambda^2, \dots, \lambda^k)$  to  $\lambda^i$  to obtain  $\nu^i$ .

Now we proceed recursively, adding one square at a time to  $\nu^1, \nu^2, \dots, \nu^k$  until we have inserted parts whose sum is  $a$ .

To add one more box to the sequence of partitions:

If the selected part of  $\nu^1$  is the first part, add one to this part.

Otherwise, find the partition  $\nu^i$  with smallest index  $i$  such that the selected part of  $\nu^i$  is strictly less than the part above it or is strictly less than  $p_i$  if it is the first part, and add one to this part.

When we have added a total of  $a$  boxes, let  $\mu^1, \mu^2, \dots, \mu^k$  be the resulting partitions. We have

$$\phi(a; \lambda^1, \lambda^2, \dots, \lambda^k) = (\mu^1, \mu^2, \dots, \mu^k).$$

This could be used as a definition for  $\phi$ , and in this context Proposition 4.1.2 would show that  $\phi$  is well-defined.

Proposition 4.1.2 also shows that  $\phi$  is reversible since the rows added by  $\phi$  are those selected when calculating  $A(\mu^1, \mu^2, \dots, \mu^k)$  and  $a = A(\mu^1, \mu^2, \dots, \mu^k)$ . We will also use the inverse maps which we will call  $\psi$ . If  $\phi(a; \lambda^1, \lambda^2, \dots, \lambda^k) = (\mu^1, \mu^2, \dots, \mu^k)$ , let

$$\psi_{\{p_2, \dots, p_k\}}(\mu^1, \mu^2, \dots, \mu^k) = \psi(\mu^1, \mu^2, \dots, \mu^k) = (a; \lambda^1, \lambda^2, \dots, \lambda^k),$$

and

$$\begin{aligned} \psi_1(\mu^1, \mu^2, \dots, \mu^k) &= a, \\ \psi_2(\mu^1, \mu^2, \dots, \mu^k) &= (\lambda^1, \lambda^2, \dots, \lambda^k). \end{aligned}$$

Of course, the algorithm for evaluating  $\psi$  is simple.

**Description of  $\psi$** 

Let  $\mu^1, \mu^2, \dots, \mu^k$  be a sequence of partitions such that

$$f(\mu^2) \leq p_2, f(\mu^3) \leq p_3, \dots, f(\mu^k) \leq p_k.$$

We have  $\psi(\mu^1, \mu^2, \dots, \mu^k) = (\psi_1; \psi_2)$  where

- $\psi_1 = \psi_1(\mu^1, \mu^2, \dots, \mu^k) = A(\mu^1, \mu^2, \dots, \mu^k)$ , and
- $\psi_2 = \psi_2(\mu^1, \mu^2, \dots, \mu^k) = (\lambda^1, \lambda^2, \dots, \lambda^k)$  where  $\lambda^1, \lambda^2, \dots, \lambda^k$  are found by removing the parts of  $\mu^1, \mu^2, \dots, \mu^k$  selected while calculating  $\psi_1$ .

Finally, we note that we can apply  $\psi$  to any sequence of  $k$  partitions  $\mu^1, \mu^2, \dots, \mu^k$  such that

$$f(\mu^2) \leq p_2, f(\mu^3) \leq p_3, \dots, f(\mu^k) \leq p_k.$$

It will be useful to formally note the following two consequences of Proposition 4.1.2:

**Corollary 4.1.5.** 1. For any sequence of  $k$  partitions  $\lambda^1, \lambda^2, \dots, \lambda^k$  such that

$$f(\lambda^2) \leq p_2, f(\lambda^3) \leq p_3, \dots, f(\lambda^k) \leq p_k$$

and integer  $a$  such that  $A(\lambda^1, \lambda^2, \dots, \lambda^k; p_2, \dots, p_k) \leq a$  we have

$$\psi(\phi(a; \lambda^1, \lambda^2, \dots, \lambda^k)) = (a; \lambda^1, \lambda^2, \dots, \lambda^k).$$

2. For any sequence of  $k$  partitions  $\mu^1, \mu^2, \dots, \mu^k$  such that

$$f(\mu^2) \leq p_2, f(\mu^3) \leq p_3, \dots, f(\mu^k) \leq p_k$$

we have

$$\phi(\psi(\mu^1, \mu^2, \dots, \mu^k)) = (\mu^1, \mu^2, \dots, \mu^k).$$

As a final remark, we note that if  $\psi_2(\mu^1, \mu^2, \dots, \mu^k) = (\lambda^1, \lambda^2, \dots, \lambda^k)$ , then

$$f(\lambda^2) \leq p_2, f(\lambda^3) \leq p_3, \dots, f(\lambda^k) \leq p_k.$$

Therefore we can apply  $\psi_1$  or  $\psi_2$  to  $\lambda^1, \lambda^2, \dots, \lambda^k$  and in general we can reapply  $\psi_2$  any number of times. The following lemma describes what happens when  $\psi_2$  is applied repeatedly. See Figure 4-6.

**Lemma 4.1.6.** For any sequence of  $k$  partitions  $\mu^1, \mu^2, \dots, \mu^k$  such that

$$f(\mu^2) \leq p_2, f(\mu^3) \leq p_3, \dots, f(\mu^k) \leq p_k$$

the selected rows of  $\psi_2(\mu^1, \mu^2, \dots, \mu^k)$  are rows that sit strictly below the selected rows of  $\mu^1, \mu^2, \dots, \mu^k$  in  $\mu^1, \mu^2, \dots, \mu^k$ .

In particular we have

$$A(\psi_2(\mu^1, \mu^2, \dots, \mu^k); p_2, p_3, \dots, p_k) \leq A(\mu^1, \mu^2, \dots, \mu^k; p_2, p_3, \dots, p_k).$$

*Proof.* This follows by a simple inductive argument.

Let  $\psi_2(\mu^1, \mu^2, \dots, \mu^k) = (\nu^1, \nu^2, \dots, \nu^k)$ . In both  $\mu^k$  and  $\nu^k$  we select the first part. However, the first part of  $\nu^k$  is the second part of  $\mu^k$  and so the result holds for  $\mu^k$  and  $\nu^k$ .

Moreover if the result is true for  $\mu^i$  and  $\nu^i$ , and if we selected the  $h$ th row of  $\mu^i$  and the  $j$ th row of  $\nu^i$ , then we have  $h \leq j$ . This implies  $\mu^i_h \geq \nu^i_j$ . Then the

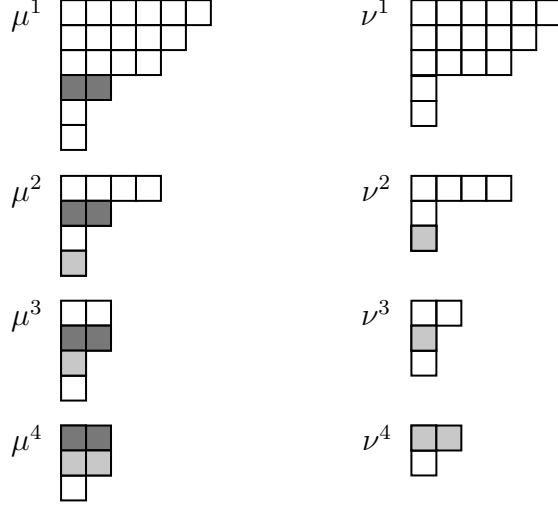

Figure 4-6: For  $p_2 = 4$ ,  $p_3 = 2$ , and  $p_4 = 3$ , we see that for  $\psi_2(\mu^1, \mu^2, \mu^3, \mu^4) = (\nu^1, \nu^2, \nu^3, \nu^4)$ . Also note that  $A(\mu^1, \mu^2, \mu^3, \mu^4) = 8 \geq A(\nu^1, \nu^2, \nu^3, \nu^4) = 4$ .

selected rows of  $\mu^{i-1}$  and  $\nu^{i-1}$  are  $h + (p_i - \mu^i_h)$  and  $j + (p_i - \nu^i_j)$  respectively and  $h + (p_i - \mu^i_h) \leq j + (p_i - \nu^i_j)$  as desired.  $\square$

The insertion procedure presented here is the central tool needed to prove the first and second symmetries as will be done in the following sections. The procedure can also be used to obtain other bijections as is shown in Appendix A.

## 4.2 First symmetry

**Theorem 4.2.1.** *For any integers  $k, n, s, t \geq 0$ , the number of partitions  $\lambda$  of  $n$  with  $k$  successive Durfee squares of widths  $N_1, N_2, \dots, N_k$  such that  $a_{k,0}(\lambda) = s$  and  $b_{k,0}(\lambda) = t$  is equal to the number of partitions  $\mu$  of  $n$  with  $k$  successive Durfee squares of widths  $N_1, N_2, \dots, N_k$  such that  $a_{k,0}(\mu) = t$  and  $b_{k,0}(\mu) = s$ .*

The following two corollaries follow immediately from the previous theorem.

**Corollary 4.2.2.** *For any integers  $k, n, r$  such that  $k, n \geq 0$ , the number of partitions  $\lambda$  of  $n$  with  $k$  successive Durfee squares of widths  $N_1, N_2, \dots, N_k$  such that  $r_{k,0}(\lambda) = r$  is equal to the number of partitions  $\mu$  of  $n$  with  $k$  successive Durfee squares of widths  $N_1, N_2, \dots, N_k$  such that  $r_{k,0}(\mu) = -r$ .*

**Corollary 4.2.3.** *For any integers  $k, n, r$  such that  $k, n \geq 0$ , the number of partitions  $\lambda$  of  $n$  with  $k$  successive Durfee squares and  $r_{k,0}(\lambda) = r$  is equal to the number of partitions  $\mu$  of  $n$  with  $k$  successive Durfee squares and  $r_{k,0}(\mu) = -r$ .*

Note that Corollary 4.2.3 is exactly Corollary 3.4.3, the first symmetry.

To prove Theorem 4.2.1 and its corollaries, we present a map,

$$\mathfrak{C}^k : \mathcal{P} \setminus \mathcal{Q}_{k-1} \rightarrow \mathcal{P} \setminus \mathcal{Q}_{k-1}.$$

Recall that

$$\mathcal{Q}_{k-1} = \{\text{partitions with at most } k-1 \text{ Durfee squares}\},$$

and so

$$\mathcal{P} \setminus \mathcal{Q}_{k-1} = \{\text{partitions with at least } k \text{ Durfee squares}\}.$$

**Definition of  $\mathfrak{C}^k$**

Let  $\lambda$  be a partition with at least  $k$  Durfee squares.

Let  $\alpha$  be the partition below the  $k$ th Durfee square of  $\lambda$  and  $\lambda^1, \lambda^2, \dots, \lambda^k$  be the partitions to the right of these squares.

Let  $N_1, N_2, \dots, N_k$  be the size of the  $k$  successive Durfee squares and let

$$p_2 = N_1 - N_2, p_3 = N_2 - N_3, \dots, p_k = N_{k-1} - N_k.$$

Let  $\beta$  be defined as follows by giving its conjugate. We remove selected rows from  $\lambda^1, \lambda^2, \dots, \lambda^k$  by using  $\psi$  to obtain:

$$\begin{aligned} \beta'_1 &= \psi_1(\lambda^1, \lambda^2, \dots, \lambda^k), \\ \beta'_2 &= \psi_1(\psi_2(\lambda^1, \lambda^2, \dots, \lambda^k)), \\ &\vdots \\ \beta'_{N_k-1} &= \psi_1(\psi_2^{N_k-2}(\lambda^1, \lambda^2, \dots, \lambda^k)), \\ \beta'_{N_k} &= \psi_1(\psi_2^{N_k-1}(\lambda^1, \lambda^2, \dots, \lambda^k)). \end{aligned}$$

We apply the map  $\psi_2$   $N_k$  times to the partitions  $\lambda^1, \lambda^2, \dots, \lambda^k$ . This gives us

$$\psi_2^{N_k}(\lambda^1, \lambda^2, \dots, \lambda^k) = (\nu^1, \nu^2, \dots, \nu^k).$$

Next we insert  $\alpha'_{N_k}, \alpha'_{N_k-1}, \dots, \alpha'_1$  into  $\nu^1, \nu^2, \dots, \nu^k$  in that order giving us

$$\phi(\alpha'_1; \phi(\alpha'_2; \dots \phi(\alpha'_{N_k-1}; \phi(\alpha'_{N_k}; \nu^1, \dots, \nu^k)) \dots)) = (\mu^1, \dots, \mu^k).$$

(continued on next page...)

Let  $\mu$  be a new partition defined by having

- $k$  successive Durfee squares of widths  $N_1, N_2, \dots, N_k$ ,
- $\mu^1, \mu^2, \dots, \mu^k$  to the right of these squares, and
- $\beta$  below the  $k$ th Durfee square.

Then  $\mathfrak{C}^k(\lambda) = \mu$ .

We will also write  $\mathfrak{C}$  for  $\mathfrak{C}^k$ .

We will give two examples of applications of  $\mathfrak{C}$  before giving the proof that  $\mathfrak{C}$  is well-defined and is an involution on  $\mathcal{P} \setminus \mathcal{Q}_{k-1}$  such that  $a_{k,m}(\lambda) = b_{k,m}(\mathfrak{C}(\lambda))$  and  $b_{k,m}(\lambda) = a_{k,m}(\mathfrak{C}(\lambda))$ . These are found in figures 4-7 and 4-8.

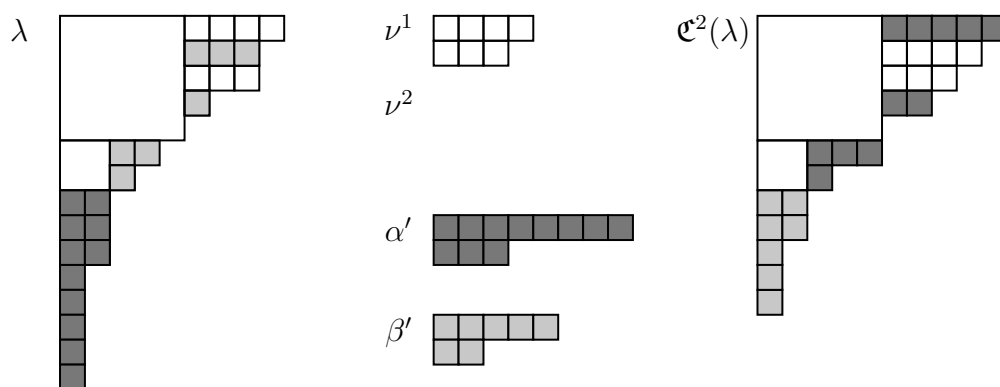

Figure 4-7: Applying  $\mathfrak{C}^2$  to the partition  $\lambda = (9, 8, 8, 6, 5, 4, 3, 2, 2, 2, 1, 1, 1, 1, 1)$ . Intermediate steps give  $\nu^1, \nu^2, \alpha',$  and  $\beta'$  as shown.

*Proof of Theorem 4.2.1.* Let  $\lambda$  be a partition with

$$a_{k,m}(\lambda) = s \text{ and} \\ b_{k,m}(\lambda) = t.$$

First we want to show that  $\mathfrak{C}$  is well-defined.

For each  $2 \leq i \leq k$ ,  $\lambda^i$  fits to the right of the  $i$ th Durfee rectangle and below the  $(i - 1)$ st Durfee rectangle. As a consequence, its largest part satisfies  $f(\lambda^i) \leq N_i - N_{i-1} = p_i$ .

Therefore, we may select parts from and apply the maps  $\psi_1$  and  $\psi_2$  to  $\lambda^1, \lambda^2, \dots, \lambda^k$ . Moreover, as we remarked at the end of the previous section, the iterated applications we do here are also fine.

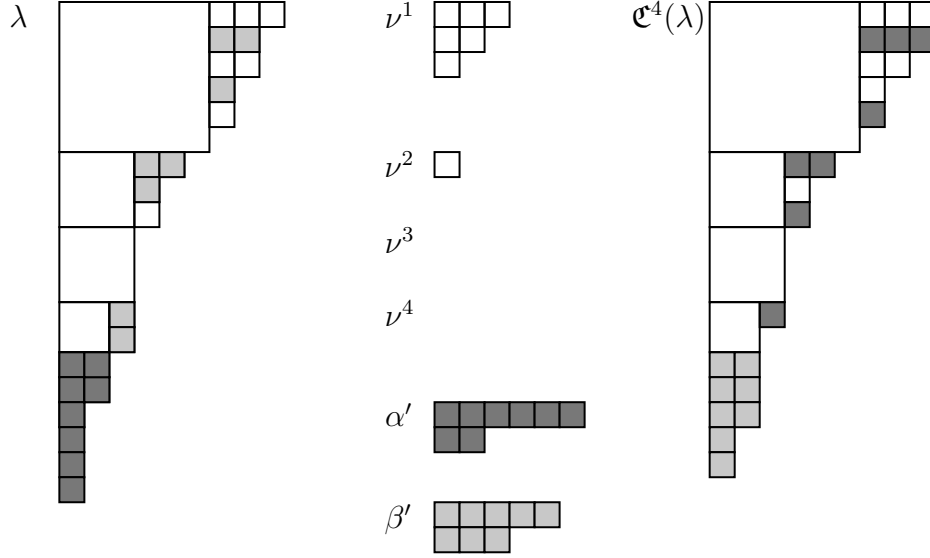

Figure 4-8: Applying  $\mathfrak{C}^4$  to  $\lambda = (9, 8, 8, 7, 7, 6, 5, 4, 4, 3, 3, 3, 3, 3, 2, 2, 1, 1, 1, 1)$ . Intermediate steps give  $\nu^1, \nu^2, \nu^3, \nu^4, \alpha',$  and  $\beta'$  as shown.

Next we want to check the  $\beta$  is a partition. To do this we need to show that

$$\beta'_1 \geq \beta'_2 \geq \dots \geq \beta'_{N_k}.$$

This follows from Lemma 4.1.6 which tells us that

$$\psi_1(\psi_2(\mu^1, \mu^2, \dots, \mu^k)) \leq \psi_1(\mu^1, \mu^2, \dots, \mu^k)$$

for any  $\mu^1, \mu^2, \dots, \mu^k$ . Since  $\beta'_1 \geq \beta'_2 \geq \dots \geq \beta'_k$ , we see that  $\beta$  a partition. Also  $\beta'$  has at most  $N_k$  parts which implies that  $f(\beta) \leq N_k$ . Therefore, we can place  $\beta$  below the  $k$ th Durfee square whose size is  $N_k$ .

Now consider

$$\psi_2^{N_k}(\lambda^1, \lambda^2, \dots, \lambda^k) = (\nu^1, \nu^2, \dots, \nu^k).$$

First we note that, since we have simply removed parts, we have

$$f(\nu^2) \leq p_2, f(\nu^3) \leq p_3, \dots, f(\nu^k) \leq p_k.$$

Moreover, for  $1 \leq i \leq k$ ,  $\nu^1$  has at most  $N_i - N_k$  parts. (In particular,  $\nu^k$  is empty.) This means that when we select parts from  $\nu^1, \nu^2, \dots, \nu^k$ , we select the  $(1 + N_i - N_k)$ th part of  $\nu^i$  which is always empty. As a consequence,  $A(\nu^1, \nu^2, \dots, \nu^k; p_2, p_3, \dots, p_k) = 0$ .

Therefore we can insert  $\alpha'_k \geq 0$  into  $\nu^1, \nu^2, \dots, \nu^k$ . As well, since  $A(\phi(\alpha'_i; \dots)) = \alpha'_i$  and  $\alpha'_i \leq \alpha'_{i-1}$  we can insert  $\alpha'_{i-1}$  into  $\phi(\alpha'_i; \dots \phi(\alpha'_{k-1}; \phi(\alpha'_{N_k}; \nu^1, \dots, \nu^k)) \dots)$ .

Finally, each of these insertions adds at most one part to each partition and does not

give partitions whose largest parts are greater than  $p_i$ . Therefore

$$f(\nu^2) \leq p_2, f(\nu^3) \leq p_3, \dots, f(\nu^k) \leq p_k$$

and, for  $1 \leq i \leq k$ ,  $\nu^i$  has at most  $(N_i - N_k) + N_k = N_i$  parts. Each  $\nu^1, \nu^2, \dots, \nu^k$  can be inserted to the right of each of the first  $k$  Durfee squares and  $\mathfrak{C}$  is well-defined.

To see that  $\mathfrak{C}$  is an involution, we simply use the relationship between  $\phi$  and  $\psi$  summarized in Corollary 4.1.5. Say  $\mathfrak{C}(\lambda) = \mu$  with  $\alpha, \beta, (\lambda^1, \lambda^2, \dots, \lambda^k)$ , and  $(\mu^1, \mu^2, \dots, \mu^k)$  as in the boxed definition. We will apply  $\mathfrak{C}$  to  $\mu$ .

Applying  $\psi$  undoes the insertions done by  $\phi$ , and we get

$$\begin{aligned} \psi_1(\mu^1, \mu^2, \dots, \mu^k) &= \psi_1(\phi(\alpha'_1; \dots)) = \alpha'_1 \text{ and} \\ \psi_1(\psi_2(\mu^1, \mu^2, \dots, \mu^k)) &= \psi_1(\psi_2(\phi(\alpha'_1; \phi(\alpha'_2; \dots)))) = \alpha'_2. \end{aligned}$$

Similarly,

$$\begin{aligned} \psi_1(\psi_2^2(\mu^1, \mu^2, \dots, \mu^k)) &= \alpha'_3, \\ &\vdots \\ \psi_1(\psi_2^{N_k-2}(\mu^1, \mu^2, \dots, \mu^k)) &= \alpha'_{N_k-1}, \\ \psi_1(\psi_2^{N_k-1}(\mu^1, \mu^2, \dots, \mu^k)) &= \alpha'_{N_k}, \end{aligned}$$

and

$$\psi_2^{N_k}(\mu^1, \mu^2, \dots, \mu^k) = (\nu^1, \nu^2, \dots, \nu^k).$$

Next we insert  $\beta'_{N_k}, \beta'_{N_k-1}, \dots, \beta'_1$  into  $\nu^1, \nu^2, \dots, \nu^k$ . Since these are the parts originally removed by  $\psi$  from  $\lambda^1, \lambda^2, \dots, \lambda^k$  to give  $\nu^1, \nu^2, \dots, \nu^k$ , we have

$$\phi(\beta'_1; \phi(\beta'_2; \dots \phi(\beta'_{N_k-1}; \phi(\beta'_{N_k}; \nu^1, \dots, \nu^k)) \dots)) = (\lambda^1, \lambda^2, \dots, \lambda^k).$$

This shows that  $\alpha$  and  $\beta$  are exchanged by  $\mathfrak{C}$  as are  $(\lambda^1, \lambda^2, \dots, \lambda^k)$  and  $(\mu^1, \mu^2, \dots, \mu^k)$  and indeed  $\mathfrak{C}$  is an involution.

Finally, we note that

$$a_{k,m}(\mu) = A(\mu^1, \mu^2, \dots, \mu^k; p_2, p_3, \dots, p_k) = \psi_1(\mu^1, \mu^2, \dots, \mu^k) = \alpha'_1 = b_{k,m}(\lambda) = t$$

and since  $\mathfrak{C}$  is an involution  $b_{k,m}(\mu) = a_{k,m}(\lambda) = s$ .  $\square$

### 4.3 Second symmetry

We also use our insertion lemma to establish the following theorem:

**Theorem 4.3.1.** *For any integers  $k, m, n, r, t$  such that  $k, n, t \geq 0$ , the number of par-*

titions  $\lambda$  of  $n$  with  $k$  successive  $m$ -Durfee rectangles, of non-zero widths  $N_1, N_2, \dots, N_k$ , with  $b_{k,m}(\lambda) = t$  and  $r_{k,m}(\lambda) \leq -r$  is equal to the number of partitions  $\mu$  of  $n - r - k(m + 1)$  with  $k$  successive  $(m + 2)$ -Durfee rectangles, of widths  $N_1 - 1, N_2 - 1, \dots, N_k - 1$ , with  $a_{k,m+2}(\mu) = t - r$  and  $b_{k,m+2}(\mu) \leq t$ .

Before proving out theorem, note that the following two corollaries follow immediately from the previous theorem.

**Corollary 4.3.2.** *For any integers  $k, m, n, r$  such that  $k, n \geq 0$ , the number of partitions  $\lambda$  of  $n$  with  $k$  successive  $m$ -Durfee rectangles, of non-zero widths  $N_1, N_2, \dots, N_k$ , with  $r_{k,m}(\lambda) \leq -r$  is equal to the number of partitions  $\mu$  of  $n - r - k(m + 1)$  with  $k$  successive  $(m + 2)$ -Durfee rectangles, of widths  $N_1 - 1, N_2 - 1, \dots, N_k - 1$ , with  $r_{k,m+2}(\mu) \geq -r$ .*

There are two situations in which the widths of the  $k$  successive  $m$ -Durfee rectangles must be non-zero.

First, since we require  $m$ -Durfee rectangles to have non-zero height, if  $m \leq 0$  then the width of the rectangles is at least  $1 - m > 0$ .

Second, if  $r > 0$  and  $r_{k,m}(\lambda) \leq -r$ , then we must have  $b_{k,m}(\lambda) \geq r > 0$ . Since  $b_{k,m}(\lambda)$  is the size of the first column of  $\alpha$  the partition which sits below the  $k$ th successive  $m$ -Durfee rectangle, notice that this  $m$ -Durfee rectangle must have non-zero width.

In the previous chapter, we only use this second symmetry when either  $m = 0$  or  $r > 0$ .

**Corollary 4.3.3.** *For any integers  $k, m, n, r$  such that  $k, n \geq 0$  and such that  $m \leq 0$  or  $r > 0$ , the number of partitions  $\lambda$  of  $n$  with  $r_{k,m}(\lambda) \leq -r$  is equal to the number of partitions  $\mu$  of  $n - r - k$  with  $r_{k,m+2}(\mu) \geq -r$ .*

Note that Corollary 4.3.3 covers the cases in Corollary 3.4.4, the second symmetry.

To prove Theorem 4.3.1 and its corollaries, we present a family of maps,

$$\mathfrak{D}_r^{k,m} : \mathcal{A} \rightarrow \mathcal{B},$$

between the following two sets:

$$\begin{aligned} \mathcal{A} &= \{\text{partitions with } k \text{ successive } m\text{-Durfee rectangles of non-zero} \\ &\quad \text{width with } (k, m)\text{-rank at most } -r\}, \\ \mathcal{B} &= \{\text{partitions with } (k, m + 2)\text{-rank at least } -r\}. \end{aligned}$$

**Definition of  $\mathfrak{D}_r^{k,m}$**

Let  $\lambda$  be a partition with  $r_{k,m}(\lambda) \leq -r$ .

Let  $\alpha$  be the partition below the  $k$ th  $m$ -Durfee rectangle and  $\lambda^1, \lambda^2, \dots, \lambda^k$  be the partitions to the right of the rectangles.

Let  $N_1, N_2, \dots, N_k$  be the widths of the  $k$  successive  $m$ -Durfee rectangles and let

$$p_2 = N_1 - N_2, p_3 = N_2 - N_3, \dots, p_k = N_{k-1} - N_k.$$

Say  $\ell(\alpha) = t$ . Then we obtain  $k$  new partitions  $\mu^1, \mu^2, \dots, \mu^k$  by applying the insertion lemma so that

$$\phi(\lambda^1, \dots, \lambda^k; t - r) = (\mu^1, \dots, \mu^k).$$

Remove the first column from  $\alpha$  (or equivalently subtract 1 from each part) to get a partition  $\beta$ .

Let  $\mu$  be a new partition defined by having

- $k$  successive  $(m+2)$ -Durfee rectangles of widths  $N_1 - 1, N_2 - 1, \dots, N_k - 1$ ,
- $\mu^1, \mu^2, \dots, \mu^k$  to the right of these rectangles, and
- $\beta$  below the  $k$ th rectangle.

Then  $\mathfrak{D}_r^{k,m}(\lambda) = \mu$ .

When  $k$  and  $m$  are clear from context we will write  $\mathfrak{D}_r$ .

We will give three examples of applications of  $\mathfrak{D}_r$  before giving the proof that  $\mathfrak{D}_r$  is well-defined and gives a bijection between  $\mathcal{A}$  and  $\mathcal{B}$  that has the desired properties. See Figures 4-9, 4-10, and 4-11.

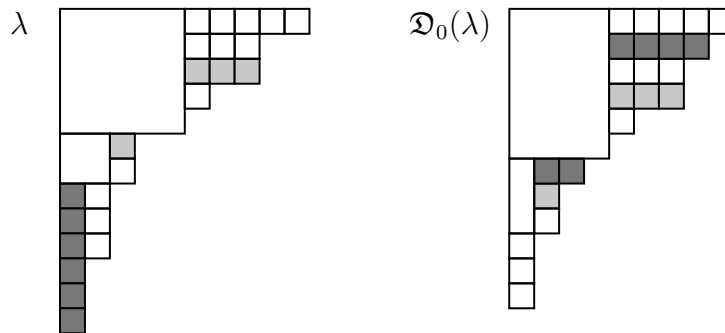

Figure 4-9: Applying  $\mathfrak{D}_0^{2,0}$  to  $\lambda = (10, 8, 8, 6, 5, 3, 3, 2, 2, 2, 1, 1, 1)$ .

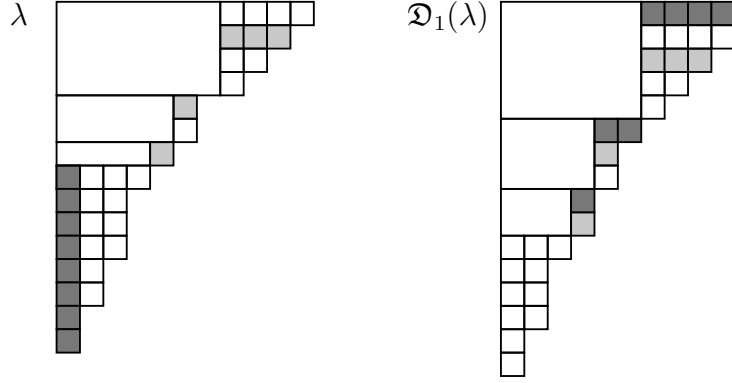

Figure 4-10: Applying  $\mathfrak{D}_1^{3,-3}$  to  $\lambda = (11, 10, 9, 8, 6, 6, 5, 4, 3, 3, 3, 2, 2, 1, 1)$ .

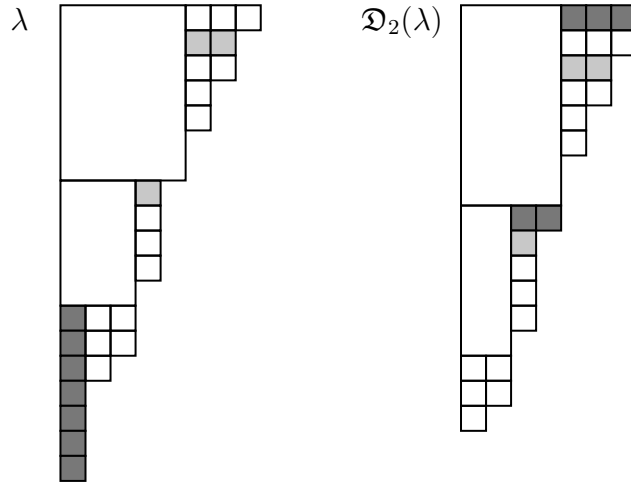

Figure 4-11: Applying  $\mathfrak{D}_2^{2,2}$  to  $\lambda = (8, 7, 7, 6, 6, 5, 5, 4, 4, 4, 4, 3, 3, 3, 2, 1, 1, 1, 1)$ .

*Proof.* Consider a partition  $\lambda$  with  $r_{k,m}(\lambda) \leq -r$ .

Say

$$\begin{aligned} a_{k,m}(\lambda) &= s, \\ b_{k,m}(\lambda) &= t. \end{aligned}$$

First, we note that  $\mu$  may have  $(m+2)$ -Durfee squares of width  $N_1-1, N_2-1, \dots, N_k-1$  since none of these integers are negative.

Next we want to apply our insertion procedure and so we must verify that the conditions of Proposition 4.1.2 are satisfied. For each  $2 \leq i \leq k$ ,  $\lambda^i$  fits to the right of the  $i$ th Durfee rectangle and below the  $(i-1)$ st Durfee rectangle. As a consequence, its largest part satisfies  $f(\lambda^i) \leq N_i - N_{i-1} = p_i$ .

Moreover, we want to insert  $t-r$  into  $\lambda^1, \lambda^2, \dots, \lambda^k$ . Since  $r_{k,m}(\lambda) = s-t \leq -r$ , we get  $A(\lambda^i, \lambda^2, \dots, \lambda^k; p_2, p_3, \dots, p_k) = a_{k,m}(\lambda) = s \leq t-r$  which is the required condition.

Now applying the lemma gives partitions  $\mu^1, \mu^2, \dots, \mu^k$  by adding one part to each of  $\lambda^1, \lambda^2, \dots, \lambda^k$ . Since we also get  $f(\mu^i) \leq p_i = (N_i - 1) - (N_{i-1} - 1)$  we see that  $\mu^1, \mu^2, \dots, \mu^k$  will fit to the right of the first  $k$  successive  $(m + 2)$ -Durfee squares of width  $N_1 - 1, N_2 - 1, \dots, N_k - 1$ .

Finally, the largest part of  $\beta$  is at least one less than the largest part of  $\alpha$  and so  $\beta$  fits under the  $k$ th successive  $(m + 2)$ -Durfee rectangle of  $\mu$ .

We may conclude that  $\mu$  is a well-defined partition.

Consider the properties of  $\mu$ . We note that:

- by definition  $\mu$  is a partition with  $k$  successive  $(m + 2)$ -Durfee rectangles of widths  $N_1 - 1, N_2 - 1, \dots, N_k - 1$ ,
- since we inserted  $t - r$  into  $\lambda^1, \lambda^2, \dots, \lambda^k$  we get

$$a_{k,m}(\mu) = A(\mu^1, \mu^2, \dots, \mu^k; p_2, p_3, \dots, p_k) = t - r,$$

- since  $\ell(\alpha) = t$  we get

$$b_{k,m}(\mu) = \ell(\beta) \leq \ell(\alpha) = t, \text{ and}$$

- if  $\lambda$  is a partition of  $n$ ,  $\mu$  is a partition of  $n - r$  since we remove a column of height  $t$  from  $\alpha$  to get  $\beta$  and insert  $t - r$  into  $\lambda^1, \lambda^2, \dots, \lambda^k$  to get  $\mu^1, \mu^2, \dots, \mu^k$ .

For the two corollaries we note that  $r_{k,m+2}(\mu) = a_{k,m+2}(\mu) - b_{k,m+2}(\mu) \geq t - r - t = -r$ .

To finish we must show that  $\mathfrak{D}_r$  is a bijection. Notice that  $\mathfrak{D}_r$  is reversible since

$$\begin{aligned} \psi_1(\mu^1, \mu^2, \dots, \mu^k) &= t - r, \text{ and} \\ \psi_2(\mu^1, \mu^2, \dots, \mu^k) &= (\lambda^1, \lambda^2, \dots, \lambda^k). \end{aligned}$$

From this we can also recover  $\alpha$  since we know  $\beta$  and  $\ell(\alpha) = t = t - r + r$ .

To show that  $\mathfrak{D}_r$  is surjective, consider *any* partition  $\mu$  with  $k$  successive  $(m+2)$ -Durfee rectangles of widths  $N_1 - 1, N_2 - 1, \dots, N_k - 1$  with  $r_{k,m+2}(\mu) \geq -r$ . Equivalently, we may say that, for some  $t$ ,  $\mu$  has  $a_{k,m+2}(\mu) = t - r$  and  $b_{k,m+2}(\mu) \leq t$ . Let  $\mu^1, \mu^2, \dots, \mu^k$  be the partitions to the right of the  $k$  successive  $(m + 2)$ -Durfee rectangles and let  $\beta$  be the partition below the  $k$ th successive  $(m + 2)$ -Durfee rectangle.

If we apply  $\psi$  as above, we obtain partitions  $\lambda^1, \lambda^2, \dots, \lambda^k$  of the appropriate size to put to the right of  $m$ -Durfee rectangles of width  $N_1, N_2, \dots, N_k$ . We can put a column to height  $t = a_{k,m+2}(\mu) + r$  in front of  $\beta$  since  $b_{k,m+2}(\mu) \leq t$ . This partition  $\alpha$  fits below the  $k$ th  $m$ -Durfee rectangle of width  $N_k$ . This gives a partition  $\lambda$ .

If we apply  $\mathfrak{D}_k$  to  $\lambda$  we are simply reversing the steps described above and so we get  $\mathfrak{D}_r(\lambda) = \mu$ . This shows that  $\mathfrak{D}_k$  is surjective onto the set of partitions with  $k$  successive  $(m + 2)$ -Durfee rectangles.  $\square$

# Chapter 5

## Connections to other work and further questions

### 5.1 Dyson's rank and proof of Euler's pentagonal number theorem

The primary inspiration for the Rogers-Ramanujan proof of the previous two chapters is Dyson's proof of Euler's pentagonal number theorem:

$$1 = \frac{1}{(q)_\infty} \sum_{j=-\infty}^{\infty} (-1)^j q^{\frac{j(3j-1)}{2}}.$$

In [Dys44], Dyson defined the rank of a partition in order to find a combinatorial interpretation of Ramanujan's famous congruences:

$$\begin{aligned} p(5n+4) &\equiv 0 \pmod{5}, \\ p(7n+5) &\equiv 0 \pmod{7}. \end{aligned}$$

His definition is remarkably simple.

**Definition 5.1.1.** *The rank of a partition  $\lambda$  is*

$$r(\lambda) = f(\lambda) - \ell(\lambda).$$

Recall that  $f(\lambda)$  is the length of the first part of  $\lambda$  and  $\ell(\lambda)$  is the number of parts of  $\lambda$ .

Dyson conjectured that rank subdivided the partitions of  $5n+4$  into 5 equinumerous classes so that the number of partitions of  $5n+4$  with rank congruent to  $i \pmod{5}$  was  $\frac{p(5n+4)}{5}$  for all  $0 \leq i \leq 4$ . Dyson made an analogous conjecture for partitions of  $7n+5$ .

Both of these conjectures were proved by Atkin and Swinnerton-Dyer in [ASD52].

Subsequently, Dyson used this rank to obtain a simple combinatorial proof of Euler’s pentagonal theorem in [Dys69] (see also [Dys88]). It was shown in [Pak03] that this proof can be converted into a direct involutive proof, and such a proof in fact coincides with the involution obtained by Bressoud and Zeilberger [BZ85].

Dyson’s argument can be presented as follows. (In addition to Dyson’s papers, see [BG02] and [Pak03] for additional descriptions.) Let  $h(n, r)$ ,  $h(n, \leq r)$ , and  $h(n, \geq r)$  denote the number of partitions of  $n$  with rank equal to  $r$ , less than or equal to  $r$ , and greater than or equal to  $r$  respectively. Clearly, for  $n > 0$ , we observe that

$$p(n) = h(n, \leq r) + h(n, \geq r + 1)$$

and Dyson noticed two symmetries,

$$\begin{aligned} h(n, r) &= h(n, -r) \text{ and} \\ h(n, \leq r) &= h(n + r - 1, \geq r - 2). \end{aligned}$$

The first of these symmetries is a simple consequence of conjugation. The second symmetry, the “new symmetry” from the title of [Dys69], follows from a bijection,  $d_r$ , which we call Dyson’s map. Dyson’s map  $d_r$  takes a partition  $\lambda$  of  $n$  with  $r(\lambda) \leq r$  and returns a partition  $\mu$  of  $n + r - 1$  with  $r(\mu) \geq r - 2$  by removing the first column of  $\lambda$ , which has  $\ell(\lambda)$  squares, and adding a part of size  $\ell(\lambda) + r - 1$ . This new part will be the first row of  $\mu$ . See figure 5-1 for an example.

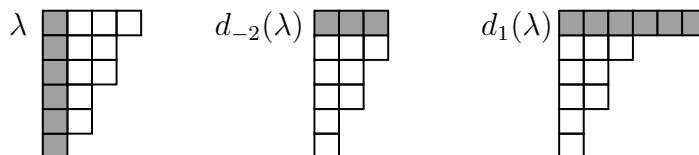

Figure 5-1: Applying Dyson’s map to  $\lambda = (4, 3, 3, 2, 2, 1)$  with  $r(\lambda) = 4 - 6 = -2$  gives  $d_{-2}(\lambda) = (3, 3, 2, 2, 1, 1)$  and  $d_1(\lambda) = (6, 3, 2, 2, 1, 1)$ .

Let

$$\begin{aligned} H_{\leq r}(q) &= \sum_{n=1}^{\infty} h(n, \leq r) q^n \text{ and} \\ H_{\geq r}(q) &= \sum_{n=1}^{\infty} h(n, \geq r) q^n \end{aligned}$$

be the generating functions for partitions with rank at most  $r$  and at least  $r$ . Then

$$H_{\leq r}(q) = q^{1-r} H_{\geq r-2}(q) = q^{1-r} \left( \frac{1}{(q)_{\infty}} - H_{\leq r-3}(q) \right)$$

where the first equality follows from Dyson’s “new symmetry” and the second equality

follows from the observation. Applying this equation repeatedly gives

$$\begin{aligned}
H_{\leq r}(q) &= q^{1-r} \left( \frac{1}{(q)_\infty} - H_{\leq r-3}(q) \right) \\
&= q^{1-r} \left( \frac{1}{(q)_\infty} \right) - q^{5-2r} \left( \frac{1}{(q)_\infty} - H_{\leq r-6}(q) \right) \\
&= q^{1-r} \left( \frac{1}{(q)_\infty} \right) - q^{5-2r} \left( \frac{1}{(q)_\infty} \right) + q^{12-3r} \left( \frac{1}{(q)_\infty} - H_{\leq r-9}(q) \right) \\
&\quad \vdots \\
&= \frac{1}{(q)_\infty} \sum_{j=1}^{\infty} (-1)^{j-1} q^{\frac{j(3j-1)}{2} - jr} .
\end{aligned}$$

Finally, the first symmetry (conjugation) gives us

$$\frac{1}{(q)_\infty} = 1 + H_{\leq 0}(q) + H_{\geq 1}(q) = 1 + H_{\leq 0}(q) + H_{\leq -1}(q)$$

and substituting gives Euler's pentagonal number theorem.

Roughly speaking, our proof of Schur's identity and its generalization to multiple Durfee squares is a Dyson-style proof with a modified Dyson's rank. We generalized Dyson's rank by defining  $(k, m)$ -rank. The algebraic steps used to deduce the generalized Schur identities are the same as those used to deduce Euler's pentagonal number theorem. Moreover, the bijections,  $\mathfrak{C}^k$  and  $\mathfrak{D}_r^{k,m}$  which we use to prove our first and second symmetries generalize conjugation and Dyson's map.

More precisely, in the case  $k = 1$ , we have:

$$\begin{aligned}
r_{1,m}(\lambda) &= r(\lambda) - m, \\
\mathfrak{C}^1 &= \text{conjugation, and} \\
\mathfrak{D}_r^{1,m} &= d_{-r-m}.
\end{aligned}$$

This is not the first generalization of Dyson's rank that has been used to prove the Rogers-Ramanujan identities. The notion of successive rank can also be used to give a combinatorial proof of the Rogers-Ramanujan identities and their generalizations by a sieve argument (see [And72, ABB<sup>+</sup>87, Bre80b]). However, this proof does not use the notion of successive Durfee squares but rather involves a different combinatorial description of the partitions on the left hand side of the Rogers-Ramanujan identities. This generalization of Dyson's rank was kindly brought to our attention by George Andrews.

## 5.2 Garvan and Berkovich

Garvan [Gar94] has also defined a generalized notion of rank for partitions with multiple Durfee squares. This definition is different from the one given in Chapter 3. However, his definition leads to same generating function as that for partitions with  $(k, 0)$ -rank at most  $-r$ , equation (3.3):

$$H_{k,0,\leq r}(q) = \frac{1}{(q)_\infty} \sum_{j=1}^{\infty} (-1)^{j-1} q^{jr+j^2k+\frac{j(j-1)}{2}}.$$

Based on this generating function, in [BG02], Berkovich and Garvan deduced that a symmetry similar to Dyson’s “new symmetry” must exist for Garvan’s generalized rank and asked for a Dyson-style proof but noted that it “turned out to be very difficult to prove in a combinatorial fashion.”

In this section we will explain the relationship between our generalization of rank and Garvan’s definition, and the two symmetries associated with both definitions. We will also be able to show why the Dyson-style proof sought by Berkovich and Garvan turns out to be difficult to find.

### 5.2.1 Equidistribution of $r_{k,0}$ and $gr_k$

**Definition 5.2.1** (Garvan, [Gar94]). *Let  $\lambda$  be a partition with at least  $k$  successive Durfee squares, where the  $k$ th Durfee square has size  $N_k$ . Define*

$$gr_k(\lambda) = \begin{array}{l} \text{the number of columns in the diagram of } \lambda \text{ which lie to the} \\ \text{right of the first Durfee square and whose length } \leq N_k \\ \text{minus} \\ \text{the number of parts of } \lambda \text{ that lie below the } k\text{th Durfee square.} \end{array}$$

Garvan called  $gr_k(\lambda)$  the  $(k + 1)$ -rank of  $\lambda$ . See Figure 5-2.

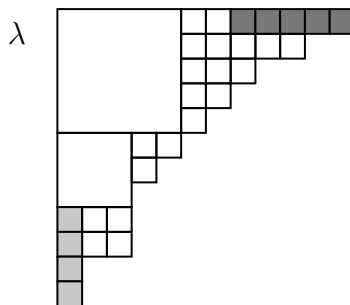

Figure 5-2: Partition  $\lambda = (12, 10, 8, 7, 6, 5, 4, 3, 3, 3, 1, 1)$  has  $ga_2(\lambda) = 5$ ,  $gb_2(\lambda) = 4$ , and  $gr_2(\lambda) = 5 - 4 = 1$ .

One first theorem tells us that  $gr_k$  and  $r_{k,0}$  have the same distribution on partitions of  $n$ .

**Theorem 5.2.2.** *For any integers  $n \geq 0$  and  $r$ , the number of partitions  $\lambda$  of  $n$  with  $r_{k,0}(\lambda) = r$  is equal to the number of partitions  $\mu$  of  $n$  with  $gr_k(\mu) = r$ .*

To give an even more precise relationship consider the following two definitions. Recall that for a partition  $\lambda$  with  $k$  successive Durfee squares, we denote the partitions to the right of these Durfee squares by  $\lambda^1, \lambda^2, \dots, \lambda^k$  and the partition below the  $k$ th Durfee square by  $\alpha$ .

**Definition 5.2.3.** *Let  $\lambda$  be a partition with at least  $k$  successive Durfee squares, where the  $k$ th Durfee square has size  $N_k$ . Define*

$$\begin{aligned} ga_k(\lambda) &= \text{the number of columns of } \lambda^1 \text{ whose length } \leq N_k, \text{ and} \\ gb_k(\lambda) &= \ell(\alpha). \end{aligned}$$

These definitions give us  $gr_k(\lambda) = ga_k(\lambda) - gb_k(\lambda)$  and we have a revised theorem which implies Theorem 5.2.2.

**Theorem 5.2.4.** *For any integers  $n, s, t \geq 0$ , the number of partitions  $\lambda$  of  $n$  with  $k$  successive Durfee squares, of size  $N_1, N_2, \dots, N_k$ , with  $a_{k,0}(\lambda) = s$  and  $b_{k,0}(\lambda) = t$  is equal to the number of partitions  $\mu$  of  $n$  with  $k$  successive Durfee squares, of size  $N_1, N_2, \dots, N_k$ , with  $ga_k(\mu) = s$  and  $gb_k(\mu) = t$ .*

The proof of this theorem will use the following lemma and the maps  $\phi$  and  $\psi$  from Chapter 4.

Let  $\mathcal{J}$  be the set of partitions with  $k$  successive Durfee squares of size  $N_1, N_2, \dots, N_k$  that have

- no part below the  $k$ th Durfee square and
- no part to the right of the bottom  $N_k$  rows of each Durfee square.

Let  $\mathcal{K}$  be the set of partitions with  $k$  successive Durfee squares of size  $N_1, N_2, \dots, N_k$  that have

- no part below the  $k$ th Durfee square and
- no column to the right of the first Durfee square whose length is  $\leq N_k$ .

See Figure 5-3 for an example of these types of partitions.

**Lemma 5.2.5.** *The number of partitions of  $n$  in  $\mathcal{J}$  is equal to the number of partitions  $n$  in  $\mathcal{K}$ .*

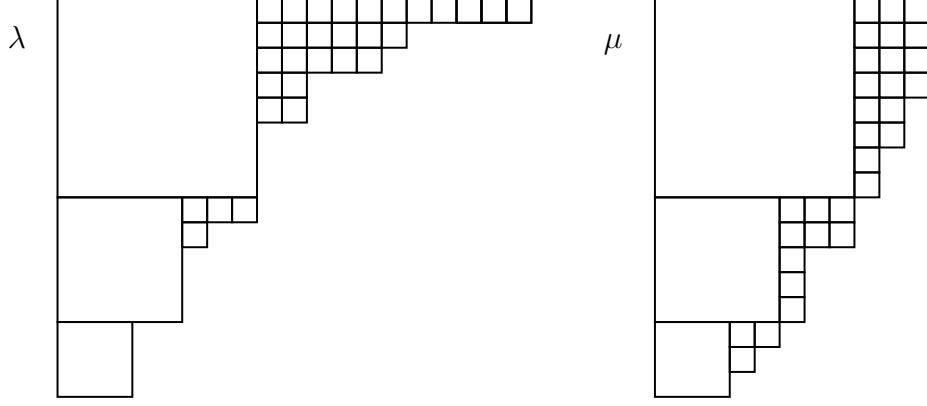

Figure 5-3: Consider partitions  $\lambda = (19, 14, 13, 10, 10, 8, 8, 8, 8, 6, 5, 5, 5, 3, 3, 3)$  and  $\mu = (11, 11, 11, 11, 10, 10, 9, 9, 8, 8, 6, 6, 6, 5, 4, 3)$  with Durfee squares of size 8, 5, and 3. Partition  $\lambda \in \mathcal{J}$  has no part to the right of the bottom 3 rows of each Durfee square. Partition  $\mu \in \mathcal{K}$  has no column of length  $\leq 3$  to the right of its first Durfee square.

*Proof.* This follows from a simple counting argument. Consider the generating function for both sets,  $\mathcal{J}$  and  $\mathcal{K}$ , with respect to the size of the partition.

The first set,  $\mathcal{J}$ , is the set of partitions with Durfee squares of size  $N_1, N_2, \dots, N_k$  and  $\lambda^1, \lambda^2, \dots, \lambda^k$  such that

$$\begin{aligned}
 \ell(\lambda^1) &\leq N_1 - N_k, \\
 \ell(\lambda^2) &\leq N_2 - N_k, & f(\lambda^2) &\leq N_1 - N_2, \\
 &\vdots & &\vdots \\
 \ell(\lambda^{k-1}) &\leq N_{k-1} - N_k, & f(\lambda^{k-1}) &\leq N_{k-2} - N_{k-1}, \\
 \ell(\lambda^k) &\leq N_k - N_k = 0, & f(\lambda^k) &\leq N_{k-1} - N_k.
 \end{aligned}$$

This gives the following generating function:

$$\begin{aligned}
 &\frac{q^{N_1^2 + N_2^2 + \dots + N_k^2}}{(q)_{N_1 - N_k}} \begin{bmatrix} N_1 - N_k \\ N_2 - N_k \end{bmatrix}_q \begin{bmatrix} N_2 - N_k \\ N_3 - N_k \end{bmatrix}_q \cdots \begin{bmatrix} N_{k-2} - N_k \\ N_{k-1} - N_k \end{bmatrix}_q \begin{bmatrix} N_{k-1} - N_k \\ 0 \end{bmatrix}_q \\
 &= \frac{q^{N_1^2 + N_2^2 + \dots + N_k^2}}{(q)_{N_1 - N_k}} \frac{(q)_{N_1 - N_k}}{(q)_{N_2 - N_k} (q)_{N_1 - N_2}} \frac{(q)_{N_2 - N_k}}{(q)_{N_3 - N_k} (q)_{N_2 - N_3}} \cdots \frac{(q)_{N_{k-2} - N_k}}{(q)_{N_{k-1} - N_k} (q)_{N_{k-2} - N_{k-1}}} \\
 &= \frac{q^{N_1^2 + N_2^2 + \dots + N_k^2}}{(q)_{N_1 - N_2} (q)_{N_2 - N_3} \cdots (q)_{N_{k-1} - N_k}}.
 \end{aligned}$$

On the other hand, the second set of partitions,  $\mathcal{K}$ , consists of those with Durfee squares of size  $N_1, N_2, \dots, N_k$  and  $\lambda^1, \lambda^2, \dots, \lambda^k$  such that

$$\begin{aligned} \ell(\lambda^1) &\leq N_1, \\ \ell(\lambda^2) &\leq N_2, & f(\lambda^2) &\leq N_1 - N_2, \\ &\vdots & &\vdots \\ \ell(\lambda^{k-1}) &\leq N_{k-1}, & f(\lambda^{k-1}) &\leq N_{k-2} - N_{k-1}, \\ \ell(\lambda^k) &\leq N_k, & f(\lambda^k) &\leq N_{k-1} - N_k. \end{aligned}$$

and such that  $\lambda^1$  has no column of length  $\leq N_k$ .

This gives the following generating function:

$$\begin{aligned} & q^{N_1^2 + N_2^2 + \dots + N_k^2} \frac{(q)_{N_k}}{(q)_{N_1}} \begin{bmatrix} N_1 \\ N_2 \end{bmatrix}_q \begin{bmatrix} N_2 \\ N_3 \end{bmatrix}_q \cdots \begin{bmatrix} N_{k-2} \\ N_{k-1} \end{bmatrix}_q \begin{bmatrix} N_{k-1} \\ N_k \end{bmatrix}_q \\ &= q^{N_1^2 + N_2^2 + \dots + N_k^2} \frac{(q)_{N_k}}{(q)_{N_1}} \frac{(q)_{N_1}}{(q)_{N_2} (q)_{N_1 - N_2}} \frac{(q)_{N_2}}{(q)_{N_3} (q)_{N_2 - N_3}} \cdots \frac{(q)_{N_{k-1}}}{(q)_{N_k} (q)_{N_{k-1} - N_k}} \\ &= \frac{q^{N_1^2 + N_2^2 + \dots + N_k^2}}{(q)_{N_1 - N_2} (q)_{N_2 - N_3} \cdots (q)_{N_{k-1} - N_k}}. \end{aligned}$$

Since the generating functions are equal, the lemma follows.  $\square$

*Proof of Theorem 5.2.4.* Let  $\alpha$  be a partition with parts of size at most  $N_k$  with  $\ell(\alpha) = t$ , and let  $\beta$  be a partition with at most  $N_k$  parts with  $f(\beta) = s$ . Say  $\alpha \vdash a$  and  $\beta \vdash b$ .

To prove the theorem, we will show how to insert  $\alpha$  and  $\beta$  into a partition  $\rho$  of size  $n - a - b$  in  $\mathcal{J}$  to obtain a partition  $\lambda$  of  $n$  with  $k$  successive Durfee squares of sizes  $N_1, N_2, \dots, N_k$  with  $a_{k,0}(\lambda) = s$  and  $b_{k,0}(\lambda) = t$ , and we will show how to insert  $\alpha$  and  $\beta$  into a partition  $\nu$  of size  $n - a - b$  in  $\mathcal{K}$  to obtain a partition  $\mu$  of  $n$  with  $k$  successive Durfee squares of sizes  $N_1, N_2, \dots, N_k$  with  $ga_k(\mu) = s$  and  $gb_k(\mu) = t$ .

In both cases, inserting  $\alpha$  is simple and is done in the same way. We append  $\alpha$  to the bottom of the  $k$ th Durfee square. Appending  $\alpha$  will give  $b_{k,0}(\lambda) = t$  or  $gb_k(\lambda) = t$ .

To insert  $\beta$  into  $\nu \in \mathcal{K}$  is similar. It simply gets appended to the right of the rightmost column of  $\nu$ . Since this column must have length greater than  $N_k$ , this can be done. This, of course, gives a partition  $\lambda$  with  $ga_k(\lambda) = s$ . Moreover, this action is reversible since  $\ell(\beta) \leq N_k$ .

To insert  $\beta$  into  $\rho \in \mathcal{J}$  we use the map  $\phi$  from Chapter 4. Let  $\rho^1, \rho^2, \dots, \rho^k$  be the

partitions to the right of the first  $k$  successive Durfee squares of  $\rho$ .

We use  $\phi$  to insert  $\beta_{N_k}, \beta_{N_k-1}, \dots, \beta_1$  into  $\rho^1, \rho^2, \dots, \rho^k$  in that order giving us

$$\phi(\beta_1; \phi(\beta_2; \dots \phi(\beta_{N_k-1}; \phi(\beta_{N_k}; \rho^1, \dots, \rho^k)) \dots)) = (\lambda^1, \lambda^2, \dots, \lambda^k).$$

As before, this will give us a partition  $\lambda$  with  $a_{k,0}(\lambda) = s$  and this action can be undone using  $\psi$ .

Figure 5-3 shows an example with  $\alpha$  and  $\beta$  inserted into each type of partition.

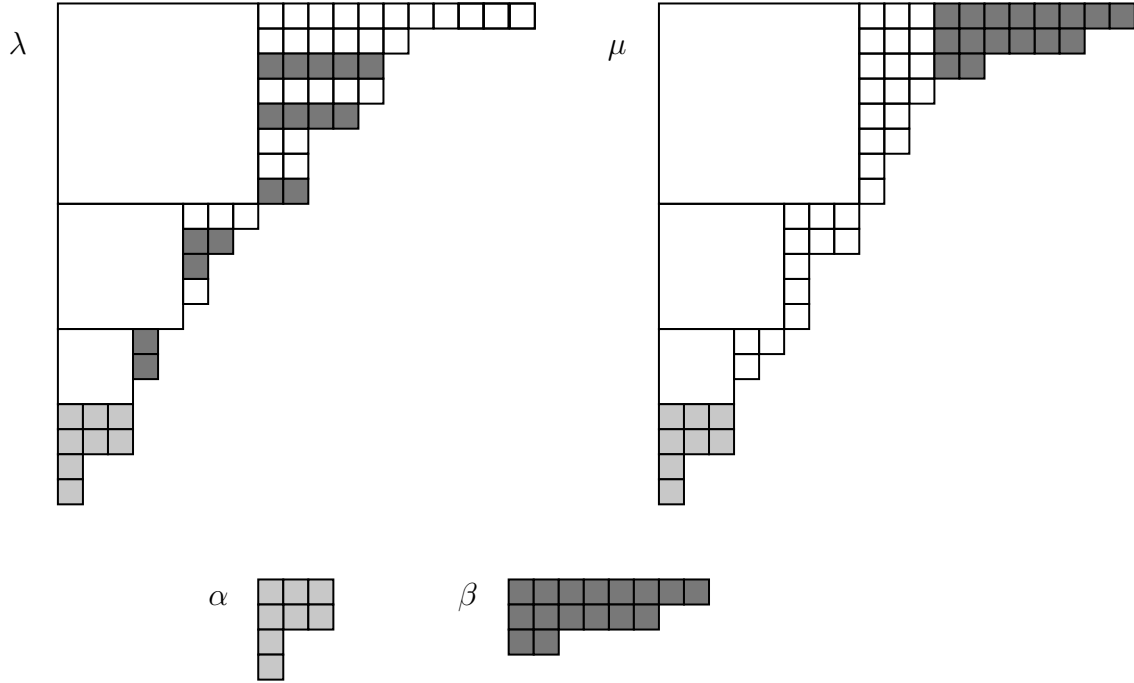

Figure 5-4: Inserting  $\alpha = (3, 3, 1, 1)$  and  $\beta = (8, 6, 2)$  into  $\lambda$  and  $\mu$  from Figure 5-3.

This gives us bijections

$$\mathcal{J} \times \{\alpha | f(\alpha) \leq N_k, \ell(\alpha) = t\} \times \{\beta | \ell(\beta) \leq N_k, f(\beta) = s\} \rightarrow$$

$$\{\lambda \text{ a partition with Durfee squares of size } N_1, N_2, \dots, N_k | a_{k,0}(\lambda) = s, b_{k,0}(\lambda) = t\}$$

and

$$\mathcal{K} \times \{\alpha | f(\alpha) \leq N_k, \ell(\alpha) = t\} \times \{\beta | \ell(\beta) \leq N_k, f(\beta) = s\} \rightarrow$$

$$\{\lambda \text{ a partition with Durfee squares of size } N_1, N_2, \dots, N_k | ga_k(\lambda) = s, gb_k(\lambda) = t\}.$$

for both bijections, the sum of the sizes of the partitions on the left hand side equals the size of the partition on the right hand side.

Together with the previous lemma, this establishes our theorem. □

Note that for any bijection  $\omega : \mathcal{J} \rightarrow \mathcal{K}$ , this proof shows how to obtain a bijection  $\Omega : \mathcal{Q}_k \rightarrow \mathcal{Q}_k$  such that  $r_{k,0}(\lambda) = gr_k(\Omega(\lambda))$ . We give such a bijection  $\omega$ , based on a map due to Franklin, in Appendix B.

### 5.2.2 Conjugation

There is a very natural definition of conjugation for Garvan's rank [Gar94].

Recall the notation from the previous section. For any partition  $\lambda$  with  $k$  successive Durfee squares of size  $N_1, N_2, \dots, N_k$ , let

- $\alpha$  be the partition below the  $k$ th Durfee square, and
- $\beta$  be the partition consisting of columns sitting to the right of the first Durfee square of  $\lambda$  whose length is  $\leq N_k$ .

The conjugate is obtained by replacing  $\alpha$  and  $\beta$  by  $\beta'$  and  $\alpha'$ , respectively. Note that conjugation is clearly an involution sends the Garvan rank of a partition to its negative. See Figure 5-5.

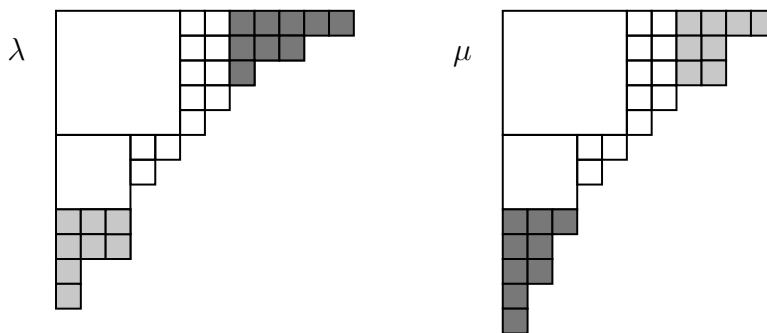

Figure 5-5: Partition  $\lambda = (12, 10, 8, 7, 6, 5, 4, 3, 3, 3, 1, 1)$  and its Garvan conjugate  $\mu = (11, 9, 9, 7, 6, 5, 4, 3, 3, 2, 2, 1, 1)$ .

The generalized version of conjugation  $\mathfrak{C}^k$  presented in Chapter 4 can be thought of in the same way except that we find  $\beta$  by removing parts from  $\lambda^1, \lambda^2, \dots, \lambda^k$  using  $\phi$  and insert  $\alpha'$  by repeatedly applying  $\psi$ .

Note that if  $\omega$  is any bijection  $\omega : \mathcal{J} \rightarrow \mathcal{K}$ , for instance the bijection given in Appendix B, and  $\Omega : \mathcal{Q}_k \rightarrow \mathcal{Q}_k$  is the corresponding bijection given by the proof of Theorem 5.2.4, then the two conjugations and  $\Omega$  commute in the following way.

$$\begin{array}{ccc}
\mathcal{Q}_k & \xrightarrow{\Omega} & \mathcal{Q}_k \\
\mathfrak{e}^k \downarrow & & \downarrow \text{Garvan's conjugation} \\
\mathcal{Q}_k & \xrightarrow{\Omega} & \mathcal{Q}_k
\end{array}$$

### 5.2.3 Dyson's map

In order to find a combinatorial proof that the generating function of partitions with  $gr_k(\lambda) \leq -r \leq 0$  is

$$\frac{1}{(q)_\infty} \sum_{j=1}^{\infty} (-1)^{j-1} q^{jr+j^2k+\frac{j(j-1)}{2}},$$

Berkovich and Garvan asked for a generalization of Dyson's map that sends partitions of  $n$  with  $gr_k(\lambda) \leq -r$  to partitions  $\lambda$  of  $n - k - r$  such that either  $\lambda$  does not have  $k$  successive Durfee squares or  $gr_k(\lambda) \geq -r - 2k$ . See equation (6.3) of [BG02].

As they remarked, this map is difficult to find. One of the reasons for this is that no such bijection can maintain the Durfee square structure of the partitions.

Considering the relationship between  $\mathfrak{e}^k$  and Garvan's conjugation, it is natural to ask how our second symmetry and, in particular, the bijection  $\mathfrak{D}_r^{k,m}$  relate to Garvan's definition. First note that such a relationship requires an expanded definition of Garvan's rank since  $\mathfrak{D}_r$  relates  $(k, m)$ -rank and  $(k, m + 2)$ -rank while Garvan's rank,  $gr_k$ , corresponds only to  $(k, 0)$ -rank.

One solution is to generalize Garvan's rank to partitions with  $k$  successive  $m$ -Durfee rectangles by considering the number of columns to the right of the first  $m$ -Durfee rectangle whose length is  $\leq N_k + m$  where  $N_k$  is the width of the  $k$ th successive  $m$ -Durfee rectangle and the number of parts of the partition that sits below the  $k$ th successive  $m$ -Durfee rectangle. The calculation in Lemma 5.2.5 and the bijections used to prove Theorem 5.2.4 work in this case and this allows us to generalize Garvan's definition of rank as desired. Moreover, the work in Appendix B can also be used to give a bijection that sends  $r_{k,m}(\lambda)$  to this generalized version of Garvan's rank.

This allows us to use  $\mathfrak{D}_r^{k,m}$  to give a generalization of Dyson's map that applies to Garvan's definition. Unfortunately, this map does not have a very nice description which is independent of the bijection from Appendix B and  $\mathfrak{D}_r^{k,m}$ .

## 5.3 Bressoud and Zeilberger

Finally, a list of work connected to this proof is not complete without mentioning the bijective Rogers-Ramanujan proof of Bressoud and Zeilberger. In [BZ82, BZ89],

they give a bijection proving Andrews' generalization of the Rogers-Ramanujan identities (3.1) based on the involution principle and Bressoud's short Rogers-Ramanujan proof [Bre83]. One of their maps,  $\Phi$  in [BZ89], acts similarly to our maps  $\mathfrak{D}_r^{k,m}$  for certain  $k$ ,  $m$ , and  $r$ . Unfortunately, due to the complexity of their proofs we do not give a formal connection. The fact that these maps are somewhat similar does however have consequences for the questions in the next section.

## 5.4 Further questions

Andrews generalized the Rogers-Ramanujan identities further. For  $1 \leq a \leq k$ , he proved that:

$$\sum_{n_1=0}^{\infty} \cdots \sum_{n_{k-1}=0}^{\infty} \frac{q^{N_1^2+N_2^2+\cdots+N_{k-1}^2+N_a+\cdots+N_{k-1}}}{(q)_{n_1}(q)_{n_2} \cdots (q)_{n_{k-1}}} = \prod_{\substack{n=1 \\ n \not\equiv 0, \pm a \pmod{2k+1}}}^{\infty} \frac{1}{1-q^n} \quad (5.1)$$

and provided a combinatorial interpretation of the left hand side as a Durfee dissection using both Durfee squares and 1-Durfee rectangles [And74, And79]. Further generalizations that lend themselves to similar interpretations have been given by Bressoud as well [Bre79, Bre80a] and by Garrett, Ismail, and Stanton [GIS99].

**Question 5.4.1.** *Can our proof be extended to prove these identities?*

It is fairly simple to extend our definition of  $(k, m)$ -rank and obtain bijections proving a first and second symmetry for these partitions in Andrews' identity. However, in this case, the second symmetry is not enough to determine the generating function for partitions with rank at most  $-r$ . In order to complete the proof, a new idea is required.

On the other hand, there is evidence that our proof will not extend. The Rogers-Ramanujan bijection given by Bressoud and Zeilberger [BZ82, BZ89] is a combinatorialization of a short proof of Bressoud [Bre83] in which he proves the following generalization of Schur's identity:

$$\begin{aligned} \sum_{s_1=0}^{\infty} \cdots \sum_{s_k=0}^{\infty} \frac{q^{s_1^2+s_2^2+\cdots+s_k^2}}{(q)_{N-s_1}(q)_{s_1-s_2} \cdots (q)_{s_{k-1}-s_k}(q)_{2s_k}} (-xq; q)_{s_k} (-x^{-1}; q)_{s_k} \\ = \frac{1}{(q)_{2N}} \sum_{j=-\infty}^{\infty} x^j q^{\frac{(2k+1)j^2+j}{2}} \left[ \begin{matrix} 2N \\ N-m \end{matrix} \right]_q. \end{aligned} \quad (5.2)$$

However, this generalization is quite different from Andrews' generalization given above. Since our map  $\mathfrak{D}_r^{k,m}$  acts similarly to one of Bressoud and Zeilberger's maps, it may be that our proof is more likely to extend to this generalization rather than equation (5.1).

If our proof were extended to either case, this would also give a proof of the second Rogers-Ramanujan identity.

As mentioned earlier, Dyson introduced rank and conjectured that it would provide a combinatorial explanation for Ramanujan's congruence results. It is natural to ask if  $(k, m)$ -rank can lead to other congruence of this type. For example,

**Question 5.4.2.** *Are there some  $n$  and  $j$  such that the partitions of  $n$  with at least  $k$  successive Durfee square are divided into equinumerous classes (mod  $j$ ) by  $(k, 0)$ -rank?*

Bijections for ordinary partitions can sometimes be extended to various classes of weighted Young diagrams. See [BY03] for numerous examples. In [BG02], Berkovich and Garvan define a version of Dyson's map for 2-modular diagrams of partitions whose odd parts are distinct and use it to prove Gauss' identity. It would be interesting to extend our bijections in this way.

**Question 5.4.3.** *Can we find versions of  $\mathfrak{C}^k$  and  $\mathfrak{D}_r^{k,m}$  for weighted Young diagrams, and what identities could we prove with these maps?*

Finally, in [Pak03], Pak shows that an iterated version of Dyson's map gives a bijection between partitions into distinct parts and partitions into odd parts.

**Question 5.4.4.** *Can we iterate our second bijection to find an analogue of this result for partitions with at least  $k$  Durfee squares?*

Note that in a sense, our generalization of conjugation  $\mathfrak{C}^k$  is defined using an iterated version of an extended Dyson's map since it uses iterations of  $\phi$  and  $\psi$ . Similarly, Zeilberger's proof of the binomial theorem, in Appendix A, can be thought of as an iteration of  $\phi$  for  $k = 2$ . It is quite likely that there are other ways of iterating  $\phi$  (or perhaps  $\mathfrak{D}_r^{k,m}$ ) that give interesting results.

# Chapter 6

## A four-parameter partition identity

In [And05], Andrews considers partitions with respect to size, number of odd parts, and number of odd parts of the conjugate. He derives the following generating function

$$\sum_{\lambda \in \mathcal{P}} r^{\theta(\lambda)} s^{\theta(\lambda')} q^{|\lambda|} = \prod_{j=1}^{\infty} \frac{(1 + rsq^{2j-1})}{(1 - q^{4j})(1 - r^2q^{4j-2})(1 - s^2q^{4j-2})}. \quad (6.1)$$

Recall that  $\mathcal{P}$  denotes the set of all partitions,  $|\lambda|$  denotes the size (sum of the parts) of  $\lambda$ ,  $\theta(\lambda)$  denotes the number of odd parts in the partition  $\lambda$ , and  $\theta(\lambda')$  denotes the number of odd parts in the conjugate of  $\lambda$ .

In this chapter, we generalize this result and provide a bijective proof of our generalization (see also [Bou05]). This provides a simple combinatorial proof of Andrews' result. As mentioned in the introduction, Stanley's work on sign-balance in posets [Sta04] and, in particular, a problem which also appeared in [Sta02] are the motivation for Andrews' identity (6.1) and for the statistics that we will use in the next section. Other combinatorial proofs of (6.1) have been found by Sills in [Sil04] and Yee in [Yee04].

### 6.1 Main result

Consider the following weight functions on the set of all partitions:

$$\begin{aligned} \alpha(\lambda) &= \sum \lceil \lambda_{2i-1}/2 \rceil, \\ \beta(\lambda) &= \sum \lfloor \lambda_{2i-1}/2 \rfloor, \\ \gamma(\lambda) &= \sum \lceil \lambda_{2i}/2 \rceil, \text{ and} \\ \delta(\lambda) &= \sum \lfloor \lambda_{2i}/2 \rfloor. \end{aligned}$$

Let  $a, b, c, d$  be (commuting) indeterminates, and define

$$w(\lambda) = a^{\alpha(\lambda)} b^{\beta(\lambda)} c^{\gamma(\lambda)} d^{\delta(\lambda)}.$$

For instance, if  $\lambda = (5, 4, 4, 3, 2)$  then  $\alpha(\lambda)$  is the number of  $a$ 's in the following diagram for  $\lambda$ ,  $\beta(\lambda)$  is the number of  $b$ 's in the diagram,  $\gamma(\lambda)$  is the number of  $c$ 's in the diagram, and  $\delta(\lambda)$  is the number of  $d$ 's in the diagram. Moreover,  $w(\lambda)$  is the product of the entries of the diagram.

$a$	$b$	$a$	$b$	$a$
$c$	$d$	$c$	$d$	
$a$	$b$	$a$	$b$	
$c$	$d$	$c$		
$a$	$b$			

These weights were first suggested by Stanley in [Sta04].

Let  $\Phi(a, b, c, d) = \sum w(\lambda)$ , where the sum is over all partitions  $\lambda$ , and let  $\Psi(a, b, c, d) = \sum w(\lambda)$ , where the sum is over all partitions  $\lambda$  with distinct parts. We obtain the following product formulas for  $\Phi(a, b, c, d)$  and  $\Psi(a, b, c, d)$ :

**Theorem 6.1.1.**

$$\Phi(a, b, c, d) = \prod_{j=1}^{\infty} \frac{(1 + a^j b^{j-1} c^{j-1} d^{j-1})(1 + a^j b^j c^j d^{j-1})}{(1 - a^j b^j c^j d^j)(1 - a^j b^j c^{j-1} d^{j-1})(1 - a^j b^{j-1} c^j d^{j-1})}.$$

**Corollary 6.1.2.**

$$\Psi(a, b, c, d) = \prod_{j=1}^{\infty} \frac{(1 + a^j b^{j-1} c^{j-1} d^{j-1})(1 + a^j b^j c^j d^{j-1})}{(1 - a^j b^j c^{j-1} d^{j-1})}.$$

Andrews' result follows easily from Theorem 6.1.1. Note that we can express the number of odd parts of  $\lambda$ , number of odd parts of  $\lambda'$  and size of  $\lambda$  in terms of the number of  $a$ 's,  $b$ 's,  $c$ 's, and  $d$ 's in the diagram for  $\lambda$  as follows:

$$\begin{aligned} \theta(\lambda) &= \alpha(\lambda) - \beta(\lambda) + \gamma(\lambda) - \delta(\lambda) \\ \theta(\lambda') &= \alpha(\lambda) + \beta(\lambda) - \gamma(\lambda) - \delta(\lambda) \\ |\lambda| &= \alpha(\lambda) + \beta(\lambda) + \gamma(\lambda) + \delta(\lambda). \end{aligned}$$

Thus we transform  $\Phi(a, b, c, d)$  by sending  $a \mapsto rsq$ ,  $b \mapsto r^{-1}sq$ ,  $c \mapsto rs^{-1}q$ , and  $d \mapsto r^{-1}s^{-1}q$ . A straightforward computation gives (6.1).

Our main result is a generalization of Theorem 6.1.1 and Corollary 6.1.2. It is the corresponding product formula in the case where we restrict the parts to some congruence class (mod  $k$ ) and we restrict the number of times those parts can occur.

Let  $R$  be a subset of positive integers congruent to  $i \pmod k$  and let  $\rho$  be a map from  $R$  to the even positive integers. Let  $\mathcal{P}(i, k; R, \rho)$  be the set of all partitions with all parts congruent to  $i \pmod k$  such that if  $r \in R$ , then  $r$  appears as a part less than  $\rho(r)$  times. Let  $\Phi_{i,k;R,\rho}(a, b, c, d) = \sum_{\lambda} w(\lambda)$  where the sum is over all partitions in  $\mathcal{P}(i, k; R, \rho)$ .

For example,  $\mathcal{P}(0, 1; \emptyset, \rho)$  is  $\mathcal{P}$ , the set of all partitions. Also, if we let  $R$  be the set of all positive integers and  $\rho$  map every positive integer to 2, then  $\mathcal{P}(0, 1; \mathbb{Z}_+, \rho)$  is the set of all partitions with distinct parts. These are the two cases found in Theorem 6.1.1 and Corollary 6.1.2.

**Theorem 6.1.3.**

$$\Phi_{i,k;R,\rho}(a, b, c, d) = ST$$

where

$$S = \prod_{j=1}^{\infty} \frac{(1 + a^{\lceil \frac{(j+1)k+i}{2} \rceil} b^{\lfloor \frac{(j+1)k+i}{2} \rfloor} c^{\lceil \frac{jk+i}{2} \rceil} d^{\lfloor \frac{jk+i}{2} \rfloor})}{(1 - a^{\lceil \frac{jk+i}{2} \rceil} b^{\lfloor \frac{jk+i}{2} \rfloor} c^{\lceil \frac{jk+i}{2} \rceil} d^{\lfloor \frac{jk+i}{2} \rfloor})(1 - a^{jk} b^{(j-1)k} c^{jk} d^{(j-1)k})}$$

and

$$T = \prod_{r \in R} (1 - a^{\lceil \frac{r}{2} \rceil} b^{\lfloor \frac{r}{2} \rfloor} c^{\lceil \frac{r}{2} \rceil} d^{\lfloor \frac{r}{2} \rfloor})$$

## 6.2 Bijective proof of Theorem 6.1.3

The proof of Theorem 6.1.3 is a slight modification of the proofs of Theorem 6.1.1 and Corollary 6.1.2. For clarity, we will first give the argument in the special cases where we consider all partitions or partitions with distinct parts, and then we will describe how the proof can be modified to work in general.

*Proof of Theorem 6.1.1.* Consider the following class of partitions:

$$\mathcal{R} = \{\lambda \in \mathcal{P} : \lambda_{2i-1} - \lambda_{2i} \leq 1\}.$$

We are restricting the difference between a part of  $\lambda$  which is at an odd level and the following part of  $\lambda$  to be at most 1.

To find the generating function for partitions in  $\mathcal{R}$  under weight  $w(\lambda)$ , we decompose  $\lambda \in \mathcal{R}$  into blocks of height 2,  $\{(\lambda_1, \lambda_2), (\lambda_3, \lambda_4), \dots\}$ . If we have an odd number of non-zero parts, add one part equal to 0. Since the difference of parts is restricted to either 0 or 1 at odd levels, we can only get two types of blocks. For any  $k \geq 1$ , we can have a block with two parts of length  $k$ , i.e.  $(k, k)$ . Call this Type I. In addition, for any  $k \geq 1$ , we can have a block with one part of length  $k$  and the other of length  $k - 1$ , i.e.  $(k, k - 1)$ . Call this Type II.

In fact, partitions in  $\mathcal{R}$  correspond uniquely to a multiset of blocks of Types I and II with at most one block of Type II for each length  $k$ . Figure 6-1 shows an example of such a decomposition.

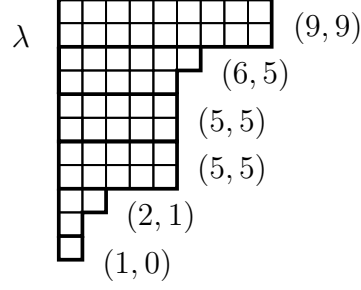

Figure 6-1:  $\lambda = (9, 9, 6, 5, 5, 5, 5, 5, 2, 1, 1)$  decomposes into blocks  $\{(9, 9), (6, 5), (5, 5), (5, 5), (2, 1), (1, 0)\}$

To calculate the generation function for  $\mathcal{R}$ , it remains to calculate the weights of our blocks. Blocks of Type I are filled as follows:

$$\begin{array}{|c|c|c|c|} \hline a & b & a & b \\ \hline c & d & c & d \\ \hline \end{array} \dots \begin{array}{|c|c|} \hline a & b \\ \hline c & d \\ \hline \end{array} \quad \text{or} \quad \begin{array}{|c|c|c|c|} \hline a & b & a & b \\ \hline c & d & c & d \\ \hline \end{array} \dots \begin{array}{|c|c|c|} \hline a & b & a \\ \hline c & d & c \\ \hline \end{array}$$

depending on the length of the blocks. Therefore they have weights  $a^j b^j c^j d^j$  or  $a^j b^{j-1} c^j d^{j-1}$ .

Blocks of Type II are filled as follows:

$$\begin{array}{|c|c|c|c|} \hline a & b & a & b \\ \hline c & d & c & d \\ \hline \end{array} \dots \begin{array}{|c|c|c|} \hline a & b & a \\ \hline c & d & \\ \hline \end{array} \quad \text{or} \quad \begin{array}{|c|c|c|c|} \hline a & b & a & b \\ \hline c & d & c & d \\ \hline \end{array} \dots \begin{array}{|c|c|} \hline a & b \\ \hline c & \\ \hline \end{array}$$

depending on the length of the blocks. Therefore they have weights  $a^j b^{j-1} c^{j-1} d^{j-1}$  or  $a^j b^j c^j d^{j-1}$ .

This gives the following generating function:

$$\sum_{\lambda \in \mathcal{R}} w(\lambda) = \prod_{j=1}^{\infty} \frac{(1 + a^j b^{j-1} c^{j-1} d^{j-1})(1 + a^j b^j c^j d^{j-1})}{(1 - a^j b^j c^j d^j)(1 - a^j b^{j-1} c^j d^{j-1})}.$$

Notice that  $\sum_{\lambda \in \mathcal{R}} w(\lambda)$  contains all the factors in  $\Phi(a, b, c, d)$  except for

$$\prod_{j=1}^{\infty} \frac{1}{1 - a^j b^j c^{j-1} d^{j-1}}.$$

Let  $\mathcal{S}$  be the set of partitions whose conjugates have only odd parts each of which is repeated an even number of times. We give a bijection  $h : \mathcal{P} \rightarrow \mathcal{R} \times \mathcal{S}$ , such that  $\mathcal{S}$  contributes exactly the missing factors.

Given a partition  $\lambda$ , let  $\nu$  be the partition with  $\lambda_{2i-1} - \lambda_{2i}$  parts equal to  $2i - 1$  if  $\lambda_{2i-1} - \lambda_{2i}$  is even and  $\lambda_{2i-1} - \lambda_{2i} - 1$  parts equal to  $2i - 1$  if  $\lambda_{2i-1} - \lambda_{2i}$  is odd. Also, let  $\mu$  be the partition defined by  $\mu_i = \lambda_i - \nu'_i$ . Let  $h(\lambda) = (\mu, \nu')$ . In other words, the map  $h$  removes as many blocks of width 2 and odd height as possible from  $\lambda$ . Call these blocks of Type III. These blocks are joined together to give  $\nu'$ . The boxes which are left behind form  $\mu$ . By definition,  $\nu$  has only odd parts, each repeated an even number of times, which implies that  $\nu' \in \mathcal{S}$ . Moreover, since we are removing as many pairs of columns of identical odd height as possible from  $\lambda$ ,  $\mu$  must have  $\lambda_{2i-1} - \lambda_{2i} \leq 1$ . To see that  $h$  is a bijection, note that its inverse is simply taking the sum of  $\mu$  and  $\nu'$  since  $\lambda_i = \mu_i + \nu'_i$ . An example is shown in Figure 6-2.

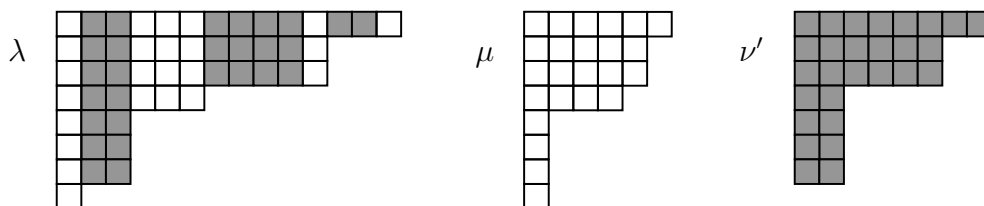

Figure 6-2:  $\lambda = (14, 11, 11, 6, 3, 3, 3, 1)$  and  $f(\lambda) = (\mu, \nu')$  where  $\nu = (7, 7, 3, 3, 3, 3, 1, 1)$  and  $\mu = (6, 5, 5, 4, 1, 1, 1, 1)$ .

Now we examine the relationship between  $w(\lambda)$ ,  $w(\mu)$ , and  $w(\nu')$ . Consider the blocks of Type III in  $\lambda$ . They always have weight  $a^j b^{j-1} c^j d^{j-1}$  regardless of whether their first column contains  $a$ 's and  $c$ 's or  $b$ 's and  $d$ 's. This is also the weight of the blocks when they are placed in  $\nu'$ . Hence  $w(\nu')$  is the product of the entries in the diagram of  $\lambda$  which are removed to get  $\mu$ .

Moreover, since we are removing columns of width 2, the entries in the squares of the diagram of  $\lambda$  that correspond to squares in the diagram on  $\mu$  do not change when  $\nu'$  is removed. This implies that  $w(\lambda) = w(\mu)w(\nu')$  and the result follows.  $\square$

*Proof of Corollary 6.1.2.* Let  $\mathcal{D}$  denote the set of partitions with distinct parts and let  $\mathcal{E}$  denote the set of partitions whose parts appear an even number of times. Then we define the following map  $g : \mathcal{P} \rightarrow \mathcal{D} \times \mathcal{E}$ . Suppose  $\lambda$  has  $k$  parts equal to  $i$ . If  $k$  is even then  $\nu$  has  $k$  parts equal to  $i$ , and if  $k$  is odd then  $\nu$  has  $k - 1$  parts equal to  $i$ . The parts of  $\lambda$  which are not removed to form  $\nu$ , at most one of each length, give  $\mu$ . Let  $g(\lambda) = (\mu, \nu)$ . An example is shown in Figure 6-3. The map  $g$  is a bijection since its inverse is taking the union of the parts of  $\mu$  and  $\nu$ . Similarly to the situation in the proof of Theorem 6.1.1, we are removing an even number of rows of each length, so  $w(\lambda) = w(\mu)w(\nu)$ .

Now using the decomposition from the proof of Theorem 6.1.1, partitions in  $\mathcal{E}$  have

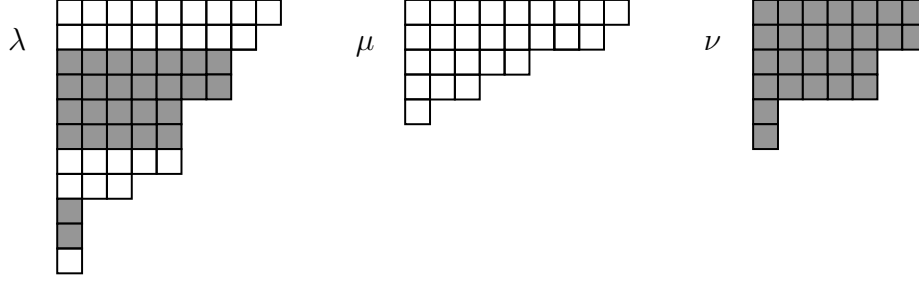

Figure 6-3:  $\lambda = (9, 8, 7, 7, 5, 5, 5, 3, 1, 1, 1)$  and  $g(\lambda) = (\mu, \nu)$  where  $\mu = (9, 8, 5, 3, 1)$  and  $\nu = (7, 7, 5, 5, 1, 1)$

a decomposition which only uses blocks of Type I. Hence

$$\Phi(a, b, c, d) = \Psi(a, b, c, d) \prod_{j=1}^{\infty} \frac{1}{(1 - a^j b^j c^j d^j)(1 - a^j b^{j-1} c^j d^{j-1})},$$

and the result follows.  $\square$

The proof of our main result follows by the same argument with a modification to the sizes of the blocks.

*Proof of Theorem 6.1.3.* First we find the generation function  $S = \Phi_{i,k;\emptyset,\rho}(a, b, c, d)$  without any restriction on the number of times each part may occur. This is done by using Type I blocks with two parts each of length  $jk + i$  for  $j \geq 1$ , Type II blocks with one part of length  $jk + i$  and one of length  $(j - 1)k + i$  for  $j \geq 1$ , and Type III blocks which are rectangular with width  $2k$  and odd height.

There is a bijection, analogous to the one in the proof of Corollary 6.1.2, between  $\mathcal{P}(i, k; \emptyset, \rho)$  and  $\mathcal{P}(i, k; R, \rho) \times \mathcal{T}$  where  $\mathcal{T}$  is the set of all partitions whose parts are in the set  $R$  and occur a multiple of  $\rho(r)$  times. Since the generating function for  $\mathcal{T}$  is

$$T^{-1} = \prod_{r \in R} \frac{1}{1 - a^{\lceil \frac{r}{2} \rceil} b^{\lfloor \frac{r}{2} \rfloor} c^{\lceil \frac{\rho(r)}{2} \rceil} d^{\lfloor \frac{\rho(r)}{2} \rfloor}},$$

we see that  $S = \Phi_{i,k;R,\rho}(a, b, c, d)T^{-1}$  and the result follows.  $\square$

# Appendix A

## Other applications of insertion

In Chapter 4 we define an insertion procedure used to describe the bijections  $\mathfrak{C}^k$  and  $\mathfrak{D}_r^{k,m}$  which generalized conjugation and Dyson's map for partitions with  $k$  successive  $m$ -Durfee rectangles. Here we present two other applications of our insertion procedure.

Neither of these applications is complicated, however they are useful examples for understand the insertion procedure and show that insertion is a natural operation on partitions.

### A.1 Formula for the $q$ -binomial coefficient

As mentioned in the introduction, equation (1.1), the generating function for partitions at most  $k$  parts of size at most  $j$  is

$$\begin{bmatrix} k+j \\ k \end{bmatrix}_q = \frac{(q)_{k+j}}{(q)_k(q)_j}.$$

Equivalently, we can write,

$$\frac{1}{(q)_k(q)_j} = \frac{1}{(q)_{k+j}} \begin{bmatrix} k+j \\ k \end{bmatrix}_q.$$

To prove this, we give a bijection  $\mathfrak{B}$  between pairs of partitions  $(\lambda, \mu)$  such that  $\lambda$  has at most  $j$  parts and  $\mu$  has at most  $k$  parts, and pairs of partitions  $(\nu, \rho)$ , such that  $\nu$  has at most  $k+j$  parts and  $\rho$  has at most  $k$  parts of size at most  $j$ . The bijection  $\mathfrak{B}$  is exactly the same as a bijection given by Zeilberger in [BZ89], though explained using different language.

**Definition of  $\mathfrak{B}$**

Suppose  $\lambda$  is a partition with at most  $j$  parts and  $\mu$  is a partition with at most  $k$  parts.

Let  $\lambda^1 = \lambda$  and  $\lambda^2$  be the empty partition. Also, let  $p_2 = j$ .

Using  $\phi$ , insert  $\mu_k, \mu_{k-1}, \dots, \mu_2, \mu_1$  into  $\lambda^1, \lambda^2$  in that order giving

$$\phi(\mu_1; \phi(\mu_2; \dots \phi(\mu_{k-1}; \phi(\mu_k; \lambda^1, \lambda^2)) \dots)) = (\nu, \rho).$$

Let  $\mathfrak{B}(\lambda, \mu) = (\nu, \rho)$ .

Since  $A(\lambda^1, \lambda^2; p_2) = 0$  insertion is defined in this case. Also the definition of  $\phi$  gives  $\nu$  with at most  $k + j$  parts and  $\rho$  with at most  $k$  parts of size at most  $j$ . Finally,  $\psi$  can be used to give the inverse maps showing that  $\mathfrak{B}$  is indeed a bijection.

In Figure A-1 we see an example of this bijection.

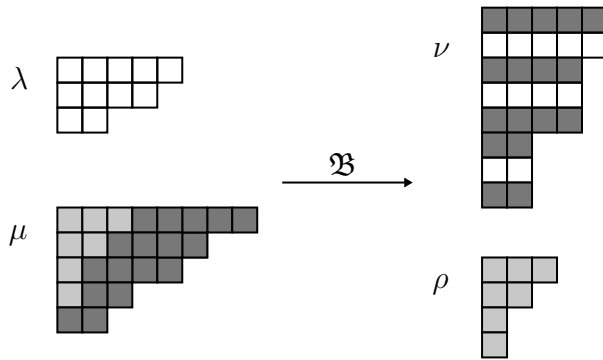

Figure A-1: Bijection  $\mathfrak{B}$  inserts  $\mu = (8, 6, 5, 3, 2)$  into  $\lambda = (5, 4, 2)$  with  $p_2 = 3$  to give partitions  $\nu = (5, 5, 4, 4, 4, 2, 2, 2)$  and  $\rho = (3, 2, 2, 1)$ .

## A.2 Generating function for partitions with successive Durfee squares

In Chapter 3, we state that the generating function for partitions with Durfee squares of size  $N_1, N_2, \dots, N_k$  and no part below the  $k$ th Durfee square is

$$\frac{q^{N_1^2 + N_2^2 + \dots + N_k^2}}{(q)_{n_1} (q)_{n_2} \dots (q)_{n_k}}$$

where  $n_k = N_k$  and  $n_j = N_j - N_{j+1}$  for  $1 \leq j \leq k - 1$ . As shown by Andrews [And79], this follows by a simple counting argument using the  $q$ -binomial coefficient and plenty

of cancellation.

We can also use  $\phi$  to establish this fact directly without cancellation using a procedure that shows from where each of the terms  $\frac{1}{(q)_i}$  comes. The bijection we use to do this is the following map  $\mathfrak{A}$ .

**Definition of  $\mathfrak{A}$**

Given the sizes of the Durfee squares,  $N_1, N_2, \dots, N_k$ , and  $k$  partitions,  $\lambda^1, \lambda^2, \dots, \lambda^k$  such that  $\lambda^i$  has at most  $n_i$  parts.

Let  $\mu^1 = \lambda^1$  and let  $\mu^2, \mu^3, \dots, \mu^k$  be empty partitions.

Let  $p_i = N_{i-1} - N_i = n_{i-1}$ .

For  $i$  from 2 to  $k$  repeat the following steps:

- Using  $\phi_{\{p_2, \dots, p_i\}}$ , insert  $\lambda_{n_i}^i, \dots, \lambda_2^i, \lambda_1^i$  into  $\mu^1, \mu^2, \dots, \mu^i$  in that order giving

$$\phi(\lambda_1^i; \phi(\lambda_2^i; \dots \phi(\lambda_{n_{i-1}}^i; \phi(\lambda_{n_i}^i; \mu^1, \mu^2, \dots, \mu^i)) \dots)) = (\nu^1, \nu^2, \dots, \nu^i).$$

- Let  $\mu^1 = \nu^1, \mu^2 = \nu^2, \dots, \mu^i = \nu^i$  and let  $\mu^{i+1}, \dots, \mu^k$  be empty partitions.

After the insertion of  $\lambda^k$ , let  $\mathfrak{A}(N_1, N_2, \dots, N_k; \lambda^1, \lambda^2, \dots, \lambda^k)$  be the partition with Durfee squares of size  $N_1, N_2, \dots, N_k$  and partitions  $\mu^1, \mu^2, \dots, \mu^k$  to the right of these Durfee squares.

The basic idea is to insert  $\lambda^1$  to the right of the first Durfee square, insert  $\lambda^2$  to the right of the first and second Durfee squares,  $\lambda^3$  to the right of the first three Durfee square, and so forth, until we have inserted  $\lambda^k$  to the right of the  $k$  successive Durfee squares giving a partition with no part below the  $k$ th Durfee square.

It is simple to check that each insertion can be done and that we get partitions  $\mu^1, \mu^2, \dots, \mu^k$  of the desired dimensions. The proof follows from the same argument that was used to show that repeated insertions gave a well-defined  $\mathfrak{C}^k$ . This being done,  $\psi$  can be used to define the inverse of  $\mathfrak{A}$  and show that it is a bijection.

Figure A-2 shows an example of  $\mathfrak{A}$ .

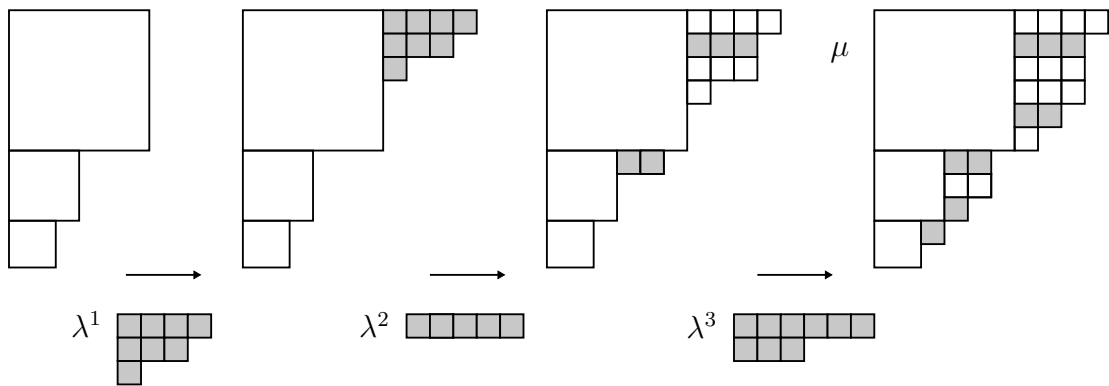

Figure A-2: Starting with three Durfee square of size  $N_1 = 6$ ,  $N_2 = 3$ , and  $N_3 = 2$ . The following three steps are shown. First, we insert  $\lambda^1 = (4, 3, 1)$  next to the first Durfee square. Second, we insert  $\lambda^2 = (5)$  next to the first two Durfee squares. Third, we insert  $\lambda^3 = (6, 3)$  next to the first three Durfee squares. This gives  $\mathfrak{A}(N_1, N_2, N_3; \lambda^1, \lambda^2, \lambda^3) = \mu = (10, 9, 9, 9, 8, 7, 5, 5, 4, 3, 2)$ .

# Appendix B

## Franklin's bijection

We note that

$$\begin{bmatrix} k+j \\ k \end{bmatrix}_q = \frac{(q)_{k+j}}{(q)_k(q)_j}$$

can be written as

$$\frac{1}{(q^k; q)_j} \begin{bmatrix} k+j \\ j \end{bmatrix}_q = \frac{1}{(q)_j}.$$

Consider the following interpretation of this identity. The right hand side is the set of all partitions with at most  $j$  parts. The left hand side the the set of all pairs of partitions, one only has parts of size between  $k+1$  and  $k+j$  and the other has at most  $j$  parts and parts of size at most  $k$ . In [SF82], Franklin gives a bijection proving this identity which we will use to define a map needed in Chapter 5.

**Definition B.0.1** (Franklin, [SF82]). *The  $i$ th excess of a partition  $\lambda$  is the  $\lambda_1 - \lambda_{i-1}$ .*

We note if a partition has at most  $j$  parts then it has parts of size at most  $k$  if and only if its  $j$ th excess is at most  $k$ .

### Definition of Franklin's bijection $\mathfrak{F}_{j,k}$

Suppose  $\lambda$  is a partition with at most  $j$  parts.

Let  $\mu = \lambda$  and let  $\nu$  be the empty partition.

Repeat until the  $j$ th excess  $\mu$  is less than or equal to  $k$ :

- Let  $i$  be such that the first through  $(i-1)$ st excess of  $\mu$  is less than or equal to  $k$  but the  $i$ th excess is at least  $k$ .
- Subtract  $k+1$  from  $\mu_1$  and 1 from  $\mu_2, \mu_3, \dots, \mu_i$ .
- Rearrange the parts to give a new partition  $\mu$  and add one part of size  $k+i$  to  $\nu$ .

When the  $j$ th excess of  $\mu$  is less than or equal to  $k$ , let  $\mathfrak{F}_{j,k}(\lambda) = (\mu, \nu)$ .

Franklin's bijection works by successively reducing the first excess until it is less than or equal to  $k$ , then reducing the second excess until it is less than or equal to  $k$ , and continuing in this fashion until the  $j$ th excess is less than or equal to  $k$ .

The proof of that  $\mathfrak{F}_{j,k}$  is a bijection is in section 20 on page 268 of [SF82].

Figures B-2 and B-1, show two examples of this bijection.

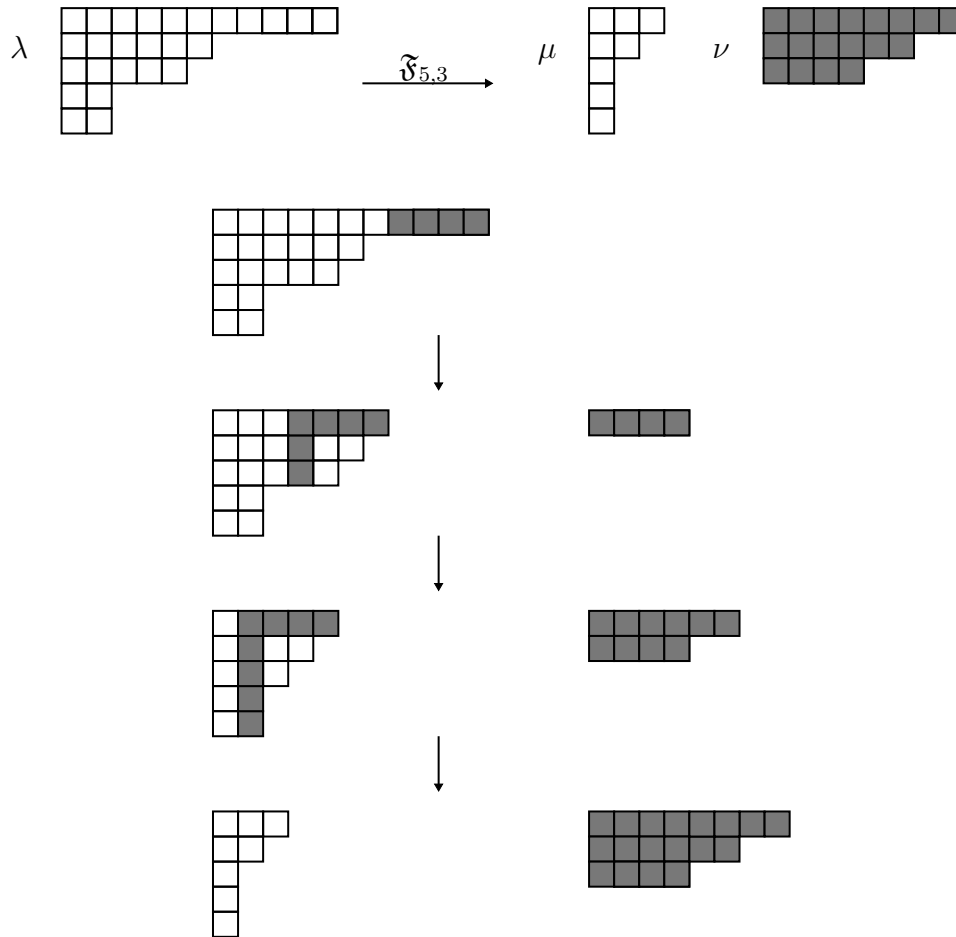

Figure B-1: Let  $j = 5$  and  $k = 3$ . Applying Franklin's bijection,  $\mathfrak{F}_{5,3}$ , to partition  $\lambda = (11, 6, 5, 2, 2)$  gives partitions  $\mu = (3, 2, 1, 1, 1)$  and  $\nu = (8, 6, 4)$ . Intermediate steps are shown with  $\mu$  on the left and  $\nu$  on the right.

In Chapter 5 we need a bijection,  $\omega$ , between partitions in the sets  $\mathcal{J}$  and  $\mathcal{K}$  where  $\mathcal{J}$  is the set of partitions with  $k$  successive Durfee squares of size  $N_1, N_2, \dots, N_k$  that have

- no part below the  $k$ th Durfee square and
- no part to the right of the bottom  $N_k$  rows of each Durfee square

and  $\mathcal{K}$  is the set of partitions with  $k$  successive Durfee squares of size  $N_1, N_2, \dots, N_k$  that have

- no part below the  $k$ th Durfee square and
- no column to the right of the first Durfee square whose length is  $\leq N_k$ .

Figure 5-3 shows an example of these types of partitions. We can use Franklin's bijection to define such a bijection  $\omega$ .

**Definition of  $\omega : \mathcal{J} \rightarrow \mathcal{K}$**

Suppose  $\rho \in \mathcal{J}$ .

Let  $\lambda$  be the partition to the right of the first Durfee square of  $\rho$ .  
Remove  $\lambda$  from  $\rho$  to get a partition  $\sigma$ .

Let  $\mathfrak{F}_{N_1-N_k, N_k}(\lambda) = (\mu, \nu)$ .

Let  $\sigma^2, \sigma^3, \dots, \sigma^k$  be the partitions to the right of the second through  $k$ th Durfee squares of  $\sigma$  and let  $p_i = N_{i-1} - N_i$  for  $3 \leq i \leq k$ .

Insert  $\mu'_{N_k}, \mu'_{N_k-1}, \dots, \mu'_1$  into the partitions  $\sigma^2, \sigma^3, \dots, \sigma^k$  using  $\phi_{\{p_3, p_4, \dots, p_k\}}$  as follows

$$\phi(\mu'_1; \phi(\mu'_2; \dots \phi(\mu'_{N_k-1}; \phi(\mu'_{N_k}; \sigma^2, \sigma^3, \dots, \sigma^k)) \dots)) = (\tau^2, \tau^3, \dots, \tau^k).$$

Let  $\tau$  be the partition obtained from  $\sigma$  by replacing  $\sigma^2, \sigma^3, \dots, \sigma^k$  by  $\tau^2, \tau^3, \dots, \tau^k$  and appending  $\nu'$  to the right of the first Durfee square.

Let  $\omega(\rho) = \tau$ .

Figure B-3 shows an example of this bijection.

The proof that  $\omega$  is a well-defined bijection follows from the same arguments that were used to prove that  $\mathfrak{C}^k$  is well-defined. There is only one new condition that must be verified. Namely,  $\tau^2$  must fit to the right of the second and below the first Durfee square and therefore we must have  $f(\tau^2) \leq N_1 - N_2$ .

Since  $f(\sigma^2) \leq N_1 - N_2$ , we must simply check that if one of the insert parts of  $\tau^2$  is its first part then it is at most  $N_1 - N_2$ . By Lemma 4.1.6, we note that the only the last application of  $\phi$  can insert a part at the top of  $\tau^2$ . Consequently, consider the selected parts of  $\tau^2, \tau^3, \dots, \tau^k$  and suppose the selected part of  $\tau^2$  is its first part. To select the first part of  $\tau^2$ , we must also have selected the first parts of  $\tau^3, \tau^4, \dots, \tau^k$  and they must have size  $p_3, p_4, \dots, p_k$ , respectively. Therefore the selected part of  $\tau^2$  has size  $\mu'_1 - p_3 - p_4 - \dots - p_k = \mu'_1 - N_2 + N_k$ . Since  $\mu'_1 \leq N_1 - N_k$  we see that the selected part of  $\tau^2$  has size at most  $N_1 - N_2$  as desired.

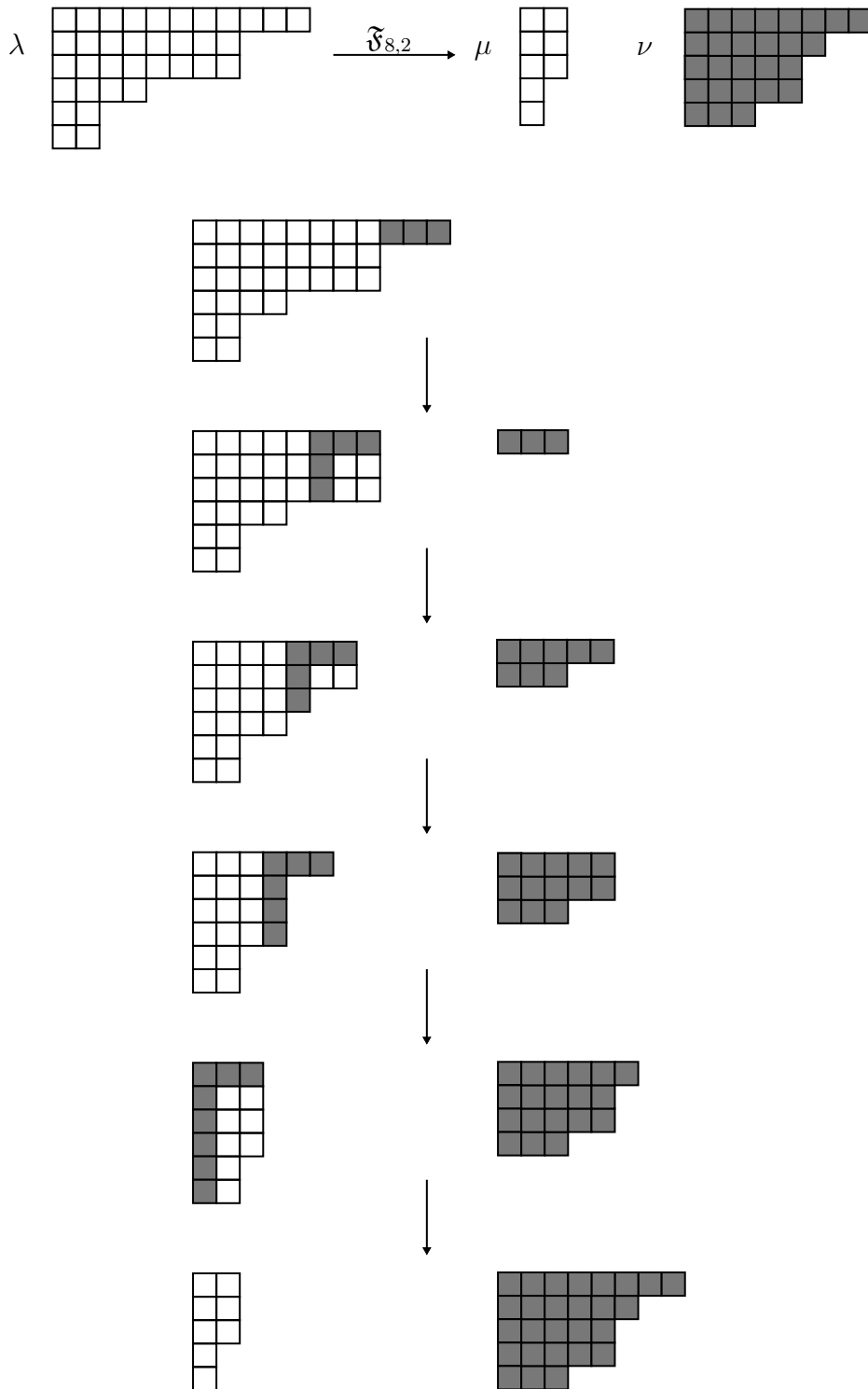

Figure B-2: Let  $j = 8$  and  $k = 2$ . Applying Franklin's bijection,  $\mathfrak{F}_{8,2}$ , to partition  $\lambda = (11, 8, 8, 4, 2, 2)$  gives partitions  $\mu = (2, 2, 2, 1, 1)$  and  $\nu = (8, 6, 5, 5, 3)$ . Intermediate steps are shown with  $\mu$  on the left and  $\nu$  on the right.

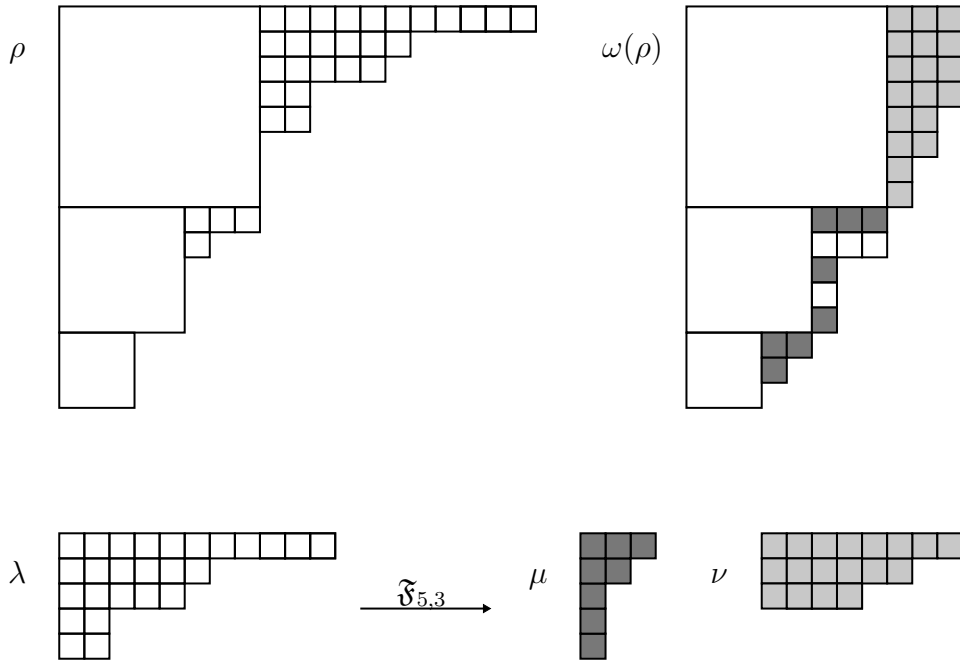

Figure B-3: Let  $\rho = (19, 14, 13, 10, 10, 8, 8, 8, 6, 5, 5, 5, 3, 3, 3)$  and let  $\lambda$  be the partition to the right of the first Durfee square. Remove  $\lambda$  from  $\rho$ . As in Figure B-1, we get  $\mathfrak{F}_{5,3}(\lambda) = (\mu, \nu)$ . Therefore we insert  $\mu'$  to the right of the second through  $k$ th Durfee squares and append  $\nu'$  to the right of the first Durfee square to obtain  $\omega(\rho) = (11, 11, 11, 11, 10, 10, 9, 9, 8, 8, 6, 6, 6, 5, 4, 3)$ .



# Bibliography

- [ABB<sup>+</sup>87] George E. Andrews, R. J. Baxter, D. M. Bressoud, W. H. Burge, P. J. Forrester, and G. Viennot. Partitions with prescribed hook differences. *European J. Combin.*, 8:341–350, 1987.
- [And72] George E. Andrews. Sieves in the theory of partitions. *Amer. J. Math.*, 94:1214–1230, 1972.
- [And74] George E. Andrews. An analytic generalization of the Rogers-Ramanujan identities for odd moduli. *Proc. Nat. Acad. Sci. USA*, 71:4082–4085, 1974.
- [And75] George E. Andrews. Partially ordered sets and the Rogers-Ramanujan identities. *Aequationes Math.*, 12:94–107, 1975.
- [And76] George E. Andrews. *The Theory of Partitions*. Addison-Wesley, Reading, MA, 1976.
- [And79] George E. Andrews. Partitions and Durfee dissection. *Amer. J. Math.*, 101:735–742, 1979.
- [And86] George E. Andrews. *q-series: their development and application in analysis, number theory, combinatorics, physics, and computer algebra*, volume 66 of *CBMS Regional Conference Series in Mathematics*. AMS, Providence, RI, 1986.
- [And05] George E. Andrews. On a partition function of Richard Stanley. *Electron. J. Combin.*, 11(2), 2004-2005. R1.
- [ASD52] A. O. L. Atkin and P. Swinnerton-Dyer. Some properties of partitions. *Proc. London Math. Soc. (3)*, 4:84–106, 1952.
- [BG02] Alexander Berkovich and Frank G. Garvan. Some observations on Dyson’s new symmetries of partitions. *J. Combin. Theory Ser. A*, 100:61–93, 2002.
- [Bou05] Cilanne E. Boulet. A four-parameter partition identity. *Ramanujan J.*, 2005. to appear.
- [BP04] Cilanne E. Boulet and Igor Pak. A new combinatorial proof of the Rogers-Ramanujan and Schur identities. 2004. preprint.

- [Bre79] David M. Bressoud. A generalization of the Rogers-Ramanujan identities for all moduli. *J. Combin. Theory Ser. A*, 27:64–68, 1979.
- [Bre80a] David M. Bressoud. An analytic generalization of the Rogers-Ramanujan identities with interpretation. *Q. J. Math.*, 31:385–399, 1980.
- [Bre80b] David M. Bressoud. Extensions of the partition sieve. *J. Number Theory*, 12:87–100, 1980.
- [Bre83] David M. Bressoud. An easy proof of the Rogers-Ramanujan identities. *J. Number Theory*, 16:235–241, 1983.
- [BY03] Bruce C. Berndt and Ae Ja Yee. Combinatorial proofs of identities in Ramanujan’s lost notebook associated with the Rogers-Fine identity and false theta functions. *Ann. Comb.*, 7(4):409–423, 2003.
- [BZ82] David M. Bressoud and Doron Zeilberger. A short Rogers-Ramanujan bijection. *Discrete Math.*, 38:313–315, 1982.
- [BZ85] David M. Bressoud and Doron Zeilberger. Bijecting Euler’s partitions-recurrence. *Amer. Math. Monthly*, 92:54–55, 1985.
- [BZ89] David M. Bressoud and Doron Zeilberger. Generalized Rogers-Ramanujan bijections. *Adv. Math.*, 78:42–75, 1989.
- [Dys44] Freeman J. Dyson. Some guesses in the theory of partitions. *Eureka (Cambridge)*, 8:10–15, 1944.
- [Dys69] Freeman J. Dyson. A new symmetry of partitions. *J. Combin. Theory*, 7:65–61, 1969.
- [Dys88] Freeman J. Dyson. *A walk through Ramanujan’s garden*, pages 7–28. Ramanujan revisited. Academic Press, Boston, MA, 1988.
- [Gar94] Frank G. Garvan. Generalizations of Dyson’s rank and non-Rogers-Ramanujan partitions. *Manuscripta Math.*, 84:343–359, 1994.
- [GIS99] K. Garrett, M. E. Ismail, and Dennis Stanton. Variants of the Rogers-Ramanujan identities. *Adv. in Appl. Math.*, 23:274–299, 1999.
- [GM81] A. M. Garsia and S. C. Milne. A Rogers-Ramanujan bijection. *J. Combin. Theory Ser. A*, 31:289–339, 1981.
- [Har40] G. H. Hardy. *Ramanujan. Twelve lectures on subjects suggested by his life and work*. Cambridge University Press, Cambridge, England, 1940.
- [Pak] Igor Pak. Rogers-Ramanujan bijections are not geometric. in preparation.
- [Pak03] Igor Pak. On Fine’s partition theorems, Dyson, Andrews, and missed opportunities. *Math. Intelligencer*, 25(1):10–16, 2003.

- [Pak05] Igor Pak. Partition bijections. *Ramanujan J.*, 2005. to appear, available from <http://www-math.mit.edu/~pak/research.html>.
- [Sch17] I. Schur. Ein Beitrag zur Additiven Zahlentheorie und zur Theorie der Kettenbrüche. *S.-B. Preuss. Akad. Wiss. Phys. Math. Klasse*, pages 302–321, 1917.
- [SF82] J. J. Sylvester and F. Franklin. A constructive theory of partitions, arranged in three acts, an interact and an exodion. *Amer. J. Math.*, 5:251–330, 1882.
- [Sil04] Andrew V. Sills. A combinatorial proof of a partition identity of Andrews and Stanley. *Int. J. Math. Math. Sci.*, 2004(47):2495–2501, 2004.
- [Sta02] Richard P. Stanley. Problem 10969. *Amer. Math. Monthly*, 109:760, 2002.
- [Sta04] Richard P. Stanley. Some remarks on sign-balanced and maj-balanced posets. *Adv. in Appl. Math.*, 2004. to appear, available from <http://www-math.mit.edu/~rstan/>.
- [Wri65] E. M. Wright. An enumerative proof of an identity of Jacobi. *J. London Math. Soc.*, 40:55–57, 1965.
- [Yee04] Ae Ja Yee. On partition functions of Andrews and Stanley. *J. Combin. Theory Ser. A*, 107(2):313–321, 2004.
- [Zei05] Doron Zeilberger. *Enumerative and algebraic combinatorics*. Princeton Companion of Mathematics. Princeton University Press, Princeton, NJ, 2005.