

Good Questions

Limits

1. **[Q]** Let f be the function defined by $f(x) = \sin x + \cos x$ and let g be the function defined by $g(u) = \sin u + \cos u$, for all real numbers x and u . Then,
 - (a) f and g are exactly the same functions
 - (b) if x and u are different numbers, f and g are different functions
 - (c) not enough information is given to determine if f and g are the same.

Answer: (a). Both f and g are given by the same rule, and are defined on the same domain, hence they are the same function.

2. **[Q] True or False.** If $f(x) = \frac{x^2 - 4}{x - 2}$ and $g(x) = x + 2$, then we can say the functions f and g are equal.

Answer: False. Note that even if the two functions have the same rule, they are defined on different domains, i.e., f is not defined at 2.

3. **[P]** Imagine that there is a rope around the equator of the earth. Add a 20 meter segment of rope to it. The new rope is held in a circular shape centered about the earth. Then the following can walk beneath the rope without touching it:
 - (a) an amoeba
 - (b) an ant
 - (c) I (the student)
 - (d) all of the above

Answer: (d). This question is quite difficult for students because it is very counter-intuitive. A little algebra needs to be done to see that as long as the student is not over $\frac{20}{2\pi}$ meters tall, she should be able to walk under the rope. Students should know or be provided with the perimeter of a circle. There is no need to know the radius of the Earth at equator. The problem encourages using a mathematical model to check one's intuition. Instructors should validate students' intuition: the change in radius is very small relative to the radius, and this may lead to the erroneous conclusion that a human would not be able to walk underneath the rope; however, a human's height is also very small relative to the radius.

4. **[P]** Given two infinite decimals $a = .3939393939\dots$ and $b = .67766777666\dots$, their sum $a + b$

- (a) is not defined because the sum of a rational and irrational number is not defined.
- (b) is not a number because not all infinite decimals are real numbers.
- (c) can be defined precisely by using successively better approximations
- (d) is not a real number because the pattern may not be predictable indefinitely.

Answer: (c). Students may be unsure about real numbers as infinite decimals. Students know that all rational numbers have terminating or repeating decimal representations. They also know that there are irrational numbers, hence there are some numbers that are represented as infinite decimals. However, they may not know that every infinite decimal represents a number (although not uniquely in the case of repeating 9's and repeating 0's) -The phrase "can be defined precisely" may cause some to reject this as a solution. In discussing this question, instructors can introduce the idea that every infinite decimal is a number and the Archimedian Axiom can help us see how we can tell whether two numbers are the same.

5. **[Q] True or False.** As x increases to 100, $f(x) = 1/x$ gets closer and closer to 0, so the limit as x goes to 100 of $f(x)$ is 0. Be prepared to justify your answer.

Answer: False. As x increases to 100, $f(x) = 1/x$ gets closer and closer to 0, gets closer and closer to $1/1000$, but not as close as to $1/100$. The question points out the weakness of the statement " $f(x)$ gets closer to L as $x \rightarrow a$, and therefore $\lim_{x \rightarrow a} f(x) = L$ ".

6. **[P] True or False.** $\lim_{x \rightarrow a} f(x) = L$ means that if x_1 is closer to a than x_2 is, then $f(x_1)$ will be closer to L than $f(x_2)$ is. Be prepared to justify your answer with an argument or counterexample.

Answer: False. Going to the limit is not monotonic! As a counterexample you can consider

$$f(x) = \begin{cases} 2x & x \geq 0 \\ -x & x < 0 \end{cases}$$

Then $\lim_{x \rightarrow 0} f(x) = 0$, and take $x_1 = 0.25$, $x_2 = -0.35$.

7. **[P]** You're trying to guess $\lim_{x \rightarrow 0} f(x)$. You plug in $x = 0.1, 0.01, 0.001, \dots$ and get $f(x) = 0$ for all these values. In fact, you're told that for all $n = 1, 2, \dots$, $f(\frac{1}{10^n}) = 0$. **True or False:** Since the sequence $0.1, 0.01, 0.001, \dots$ goes to 0, we know $\lim_{x \rightarrow 0} f(x) = 0$.

Answer: False. The goal is to see whether the students understand that it's not enough to check the limit for one particular sequence of numbers that goes to 0. The instructor may want to recall the function $\sin(\frac{\pi}{x})$ from Stewart, as x goes to 0, in order to discuss the problem. Make sure to point out this problem as an example of the danger of using calculators to "find" limits.

8. **[P]** Suppose you have an infinite sequence of closed intervals, each one contains the next, and suppose too that the width of the n th interval is less than $\frac{1}{n}$. If a and b are in each of these intervals,
- (a) a and b are very close but they don't have to be equal
 - (b) either a or b must be an endpoint of one of the intervals
 - (c) $a = b$

Answer: (c). If using this problem, the instructor should briefly talk about the Archimedian Axiom, and how intersection of nested closed intervals I_n of respective lengths $\frac{1}{n}$, is a single point. Since both a and b are in each of these I_n , this single point of intersection is $a = b$. Students have a hard time understanding the Squeeze Theorem, so this might be a good place to start in attacking that problem.

9. **[D]** Consider the function

$$f(x) = \begin{cases} x^2 & x \text{ is rational, } x \neq 0 \\ -x^2 & x \text{ is irrational} \\ \text{undefined} & x = 0 \end{cases}$$

Then

- (a) there is no a for which $\lim_{x \rightarrow a} f(x)$ exists
- (b) there may be some a for which $\lim_{x \rightarrow a} f(x)$ exists, but it is impossible to say without more information
- (c) $\lim_{x \rightarrow a} f(x)$ exists only when $a = 0$
- (d) $\lim_{x \rightarrow a} f(x)$ exists for infinitely many a

Answer: (c). Students should be encouraged to draw the graph and discuss.

10. **[Q]** The statement "Whether or not $\lim_{x \rightarrow a} f(x)$ exists, depends on how $f(a)$ is defined," is true
- (a) sometimes
 - (b) always
 - (c) never

Answer: (c). Use this problem to stress that $f(a)$ need not be defined in order for $\lim_{x \rightarrow a} f(x)$ to exist. Students have a difficult time asserting "never". The problem provides an opportunity to discuss what a limit is.

11. **[Q]** If a function f is not defined at $x = a$,

- (a) $\lim_{x \rightarrow a} f(x)$ cannot exist
- (b) $\lim_{x \rightarrow a} f(x)$ could be 0
- (c) $\lim_{x \rightarrow a} f(x)$ must approach ∞
- (d) none of the above.

Answer: (b). Answers (a) and (c) are very popular. $f(a)$ need not be defined in order for $\lim_{x \rightarrow a} f(x)$ to exist, and it does not have to approach ∞ . However, the limit could be 0, for example consider $f(x) = 0$ for all $x \neq a$, and $f(a)$ not defined. The student has to note the difference between "cannot", "could" and "must".

12. [Q] If $\lim_{x \rightarrow a} f(x) = 0$ and $\lim_{x \rightarrow a} g(x) = 0$, then $\lim_{x \rightarrow a} \frac{f(x)}{g(x)}$
- (a) does not exist
 - (b) must exist
 - (c) not enough information

Answer: (c). Point out that $\frac{0}{0}$ is not always equal to 1. If this question is used after any of the previous two problems, more students will be able to answer correctly.

The following two problems to be used in a sequence:

13. [D] The reason that $\lim_{x \rightarrow 0} \sin(1/x)$ does not exist is:
- (a) because no matter how close x gets to 0, there are x 's near 0 for which $\sin(1/x) = 1$, and some for which $\sin(1/x) = -1$
 - (b) because the function values oscillate around 0
 - (c) because $1/0$ is undefined
 - (d) all of the above

Answer: (a). Illustrate why (b) and (c) are not the reason why the limit does not exist, by introducing the next problem.

14. [D] $\lim_{x \rightarrow 0} x^2 \sin(1/x)$
- (a) does not exist because no matter how close x gets to 0, there are x 's near 0 for which $\sin(1/x) = 1$, and some for which $\sin(1/x) = -1$
 - (b) does not exist because the function values oscillate around 0
 - (c) does not exist because $1/0$ is undefined
 - (d) equals 0
 - (e) equals 1

Answer: (d). As in the previous problem, the function oscillates and $1/0$ is undefined, however, this limit exists. This is also a nice application of The Squeeze Theorem:

$$\lim_{x \rightarrow 0} (-x^2) \leq \lim_{x \rightarrow 0} x^2 \sin(1/x) \leq \lim_{x \rightarrow 0} x^2$$

Therefore, the limit equals 0.

15. [D] Suppose you have two linear functions f and g shown below.

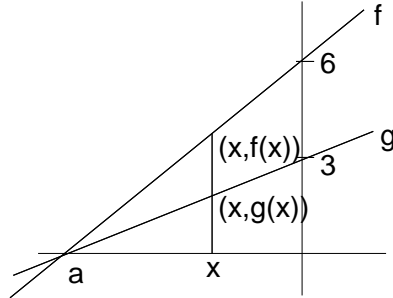

Then $\lim_{x \rightarrow a} \frac{f(x)}{g(x)}$ is

- (a) 2
- (b) does not exist
- (c) not enough information
- (d) 3

Answer: (a). This problem requires a geometrical argument:

Solution 1: By similar triangles, $\frac{f(x)}{6} = \frac{x-a}{0-a} = \frac{g(x)}{3}$, and therefore $\frac{f(x)}{g(x)} = \frac{6}{3} = 2$.

Solution 2:

$$\lim_{x \rightarrow a} \frac{f(x)}{g(x)} = \lim_{x \rightarrow a} \frac{\frac{f(x)}{-a}}{\frac{g(x)}{-a}} = \lim_{x \rightarrow a} \frac{\text{slope of } f}{\text{slope of } g} = \frac{6}{3} = 2$$

This problem is a nice preview of L'Hospital's Rule.

16. [Q] **True** or **False**. Consider a function $f(x)$ with the property that $\lim_{x \rightarrow a} f(x) = 0$. Now consider another function $g(x)$ also defined near a . Then $\lim_{x \rightarrow a} [f(x)g(x)] = 0$.

Answer: False. Students might justify a True answer by "zero times any number equals zero". Point out that it is possible that $\lim_{x \rightarrow a} g(x) = \infty$. A quick counterexample can be $a = 0$, $f(x) = x$ and $g(x) = 1/x$.

17. [Q] **True** or **False**. If $\lim_{x \rightarrow a} f(x) = \infty$ and $\lim_{x \rightarrow a} g(x) = \infty$, then $\lim_{x \rightarrow a} [f(x) - g(x)] = 0$.

Answer: False. Students might be thinking that ∞ is a number, and therefore $\infty - \infty = 0$. As a quick counterexample, consider $f(x) = x^2$ and $g(x) = x$.

18. [P] Suppose you have two linear function f and g shown below.

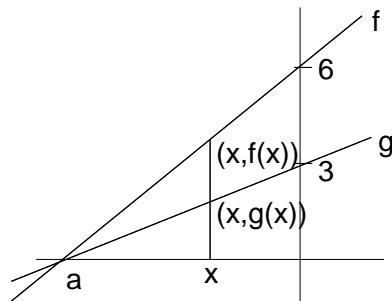

Then $\lim_{x \rightarrow \infty} \frac{f(x)}{g(x)}$ is

- (a) 2
- (b) does not exist
- (c) not enough information
- (d) 3

Answer: (a). Recall problem 6. in Section 2.3. $\frac{f(x)}{g(x)} = \frac{x-a}{0-a} = \frac{g(x)}{3}$, and therefore $\frac{f(x)}{g(x)} = \frac{6}{3} = 2$.

19. [Q] What is the maximum number of horizontal asymptotes that a function can have?
- (a) one
 - (b) two
 - (c) three
 - (d) as many as we want

Answer: (b). Students must pay attention to the way horizontal asymptotes are defined. Point out that asymptotes are defined as we go to ∞ and to $-\infty$, even though a function may have asymptotic behavior at other points.

20. [Q] **True** or **False**. A function can cross its horizontal asymptote.

Answer: True. It is easy to sketch a function that crosses its horizontal asymptote. For example, consider $\frac{\sin x}{x}$.

Continuity and Intermediate Value Theorem

1. [P] **True** or **False**: Let $P(t)$ = the cost of parking in New York City's parking garages for t hours. So,

$$P(t) = \$20 \text{ per hour or fraction thereof}$$

For example, if you are in the garage for two hours and one minute, you pay \$60. If t_0 closely approximates some time, T , then $P(t_0)$ closely approximates $P(T)$. Be prepared to justify your answer.

Answer: False. Most students will answer correctly. However, explain how no matter how close t_0 is to T , $P(t_0)$ might not be close to $P(t)$.

2. [Q] A drippy faucet adds one milliliter to the volume of water in a tub at precisely one second intervals. Let f be the function that represents the volume of water in the tub at time t .
- (a) f is a continuous function at every time t
 - (b) f is continuous for all t other than the precise instants when the water drips into the tub
 - (c) f is not continuous at any time t
 - (d) not enough information to know where f is continuous.

Answer: (b) Students should be encouraged to draw $f(t)$ and should be able to see the answer quickly. Note that (a) can also be the correct answer, depending on the model that students use for the phenomenon: if the drop of water gradually merges with the water in the tub, the function is continuous with respect to time.

3. [P] A drippy faucet adds one milliliter to the volume of water in a tub at precisely one second intervals. Let g be the function that represents the volume of water in the tub as a function of the depth of the water, x , in the tub.
- (a) g is a continuous function at every depth x
 - (b) there are some values of x at which g is not continuous
 - (c) g is not continuous at any depth, x
 - (d) not enough information to know where g is continuous.

Answer: (a) Again, students should be encouraged to draw the graph of $g(x)$. It is interesting to compare this to the previous question. It should be pointed out the difference between the independent variables in the two problems.

4. [Q] You know the following statement is true:

If $f(x)$ is a polynomial, then $f(x)$ is continuous.

Which of the following is also true?

- (a) If $f(x)$ is not continuous, then it is not a polynomial.
- (b) If $f(x)$ is continuous, then it is a polynomial.
- (c) If $f(x)$ is not a polynomial, then it is not continuous.

Answer: (a). This may seem like an easy logic question, but students tend to have difficulties; it might be a good time to review some logic. This question prepares students for reasoning that even if differentiability implies continuity, continuity does not imply differentiability. Ask for examples of functions that are continuous, but not polynomials.

5. **[D]** You decide to estimate e^2 by squaring longer decimal approximations of $e = 2.71828\dots$
- (a) This is a good idea because e is a rational number.
 - (b) This is a good idea because $y = x^2$ is a continuous function.
 - (c) This is a bad idea because e is irrational.
 - (d) This is a good idea because $y = e^x$ is a continuous function.

Answer: (b). First recall problem 4 in section 2.1, or present that problem if you have not used it. Students might have problems differentiating between (b) and (d). Point out that we estimate e^2 by considering the limit $\lim_{x \rightarrow e} x^2$ as opposed to $\lim_{x \rightarrow 2} e^x$.

Use the following 3 problems in a sequence to illustrate the use of IVT.

6. **[Q] True or False.** You were once exactly 3 feet tall.

Answer: *True.* All students were less than 3 ft tall when they were born, and they should be taller than 3 ft, so by IVT, assuming their growth was continuous, at some point in their life they must have been 3 ft tall. Stress that students may not know WHEN exactly they were 3 feet tall. Instructors should allow the possibility that growth is not continuous, for example some students may reason that they grew by a molecule at a time.

7. **[P] True or False.** At some time since you were born your weight in pounds equaled your height in inches.

Answer: *True.* Students must consider the difference of two functions: $f(t) = \text{height}(t) - \text{weight}(t)$, functions of time. At birth, $f(\text{birth}) > 0$ and right now, $f(\text{now}) < 0$, hence by IVT $f(T) = 0$, where T is some time in the past. It is important to stress that this technique of looking at the difference of two functions is recurrent in calculus.

8. **[D] True or False.** Along the Equator, there are two diametrically opposite sites that have exactly the same temperature at the same time.

Answer: True. Do not use this problem unless you have already worked through the previous two problems. This problem is not at all intuitive. Again, students must consider a difference: the difference in temperature between the diametrically opposite sites.

9. **[Q]** Suppose that during half-time at a basketball game the score of the home team was 36 points.

True or False: There had to be at least one moment in the first half when the home team had exactly 25 points.

Answer: False. Scoring in basketball is not continuous, so the IVT does not apply here. Students will probably enjoy thinking about this problem.

10. **[D] True or False.** $x^{100} - 9x^2 + 1$ has a root in $[0, 2]$.

Answer: True. This problem is not a direct application of IVT, plugging in 0 and 2, we get positive numbers, so the student must choose some other number in $[0, 2]$ to test. Choosing 0 and 1, or 1 and 2, IVT immediately applies.

11. **[P] True or False.** The function $f(x)$ defined below is continuous at $x = 0$.

$$f(x) = \begin{cases} x^2 & x \text{ is rational} \\ -x^2 & x \text{ is irrational} \end{cases}$$

Answer: True. This problem should not be that hard if students have seen this function before.

Tangents, velocities, and other rates of change

Use the following 2 problems in a sequence.

1. [P] At $(0, 0)$ the graph of $f(x) = |x|$
 - (a) has a tangent line at $y = 0$
 - (b) has infinitely many tangent lines
 - (c) has no tangent line
 - (d) has two tangent lines $y = -x$ and $y = x$.

Answer: (c). The limit $\lim_{x \rightarrow 0} \frac{f(x) - 0}{x - 0}$ does not exist, because it equals -1 from the left, and 1 from the right. Thus, we have NO tangent line at $(0, 0)$. Students might choose any of the three answers, based on their high-school experience with tangent lines. Stress that a tangent line is not necessarily a line that touches the curve at only one point (as in the case of the circle); also a curve has a tangent line at some point $(a, f(a))$ if "zooming in" on the curve at this point, the curve looks like a line. This problem is an example of a function with infinitely many lines touching at one point, but no tangent line.

2. [P] The line tangent to the graph of $f(x) = x$ at $(0, 0)$
 - (a) is $y = 0$
 - (b) is $y = x$
 - (c) does not exist
 - (d) is not unique. There are infinitely many tangent lines.

Answer: (b). Before doing the math, students might be inclined to choose any one of the answers, based on their high-school experience with tangents. Using the definition of the tangent line, they must see that the tangent at $(0, 0)$ is a line of slope 1, passing thru $(0, 0)$. This is a problem that illustrates the existence of functions with tangent lines touching the function at infinitely many points.

3. [Q] If the radius of a circle increases from r_1 to r_2 , then the average rate of change of the area of the circle is
 - (a) less than $2\pi r_2$
 - (b) greater than $2\pi r_1$
 - (c) equal to $2\pi \frac{r_1 + r_2}{2}$
 - (d) all of the above

Answer: (d). This is a straightforward application of the definition of average rate of change. Once we get (c) as an answer, (a) and (b) follow:

$$\frac{\pi r_2^2 - \pi r_1^2}{r_2 - r_1} = \pi(r_2 + r_1) = 2\pi \frac{r_2 + r_1}{2}$$

4. [P] Consider the function

$$f(x) = \begin{cases} x^2 & x \text{ is rational} \\ -x^2 & x \text{ is irrational} \end{cases}$$

Does $f'(0)$ exist?

- (a) yes
- (b) no
- (c) not possible to tell

Answer: (a) Students should be encouraged to think about tangent lines and the definition of derivative to think about this question.

5. [P] Water is being poured into a cylindrical vase. The height of the water changes as more water is poured in. The instantaneous change in the height with respect to the volume of water in the vase

- (a) is constant
- (b) varies inversely as the cube of the radius
- (c) not enough information to tell.

Answer: (a). Since $V = \pi r^2 h$ and r is constant, V and h are proportional to each other, so that $\frac{\Delta V}{\Delta h} = \frac{\pi r^2 \Delta h}{\Delta h} = \pi r^2$, is constant.

Derivatives (using the definition)

1. [Q] **True** or **False**. The function $f(x) = x^{1/3}$ is continuous at $x = 0$.

Answer: True. This is an easy check.

2. [Q] **True** or **False**. If $f(x) = x^{1/3}$ then $f'(0)$ exists.

Answer: False. $f'(0)$ equals the slope of the tangent at $(0, 0)$.

3. [P] **True** or **False**. If $f(x) = x^{1/3}$ then there is a tangent line at $(0, 0)$.

Answer: True. This gets students to think about tangent lines and derivatives. A vertical tangent line exists, although the derivative does not.

4. [P] **True** or **False**. The function $f(x) = |x|$ has a derivative at $x = 0$.

Answer: False. The limit $\lim_{x \rightarrow 0} \frac{f(x) - 0}{x - 0}$ does not exist, because it equals -1 from the left, and 1 from the right. Thus $f'(0)$ does not exist.

5. [Q] **True** or **False**. The function $g(x) = x|x|$ has a derivative at $x = 1$.

Answer: True. Easy application of the limit definition of derivative. Students should note that close to 1 , $|x| = x$. $g'(1) = 2$.

6. [P] The derivative of $f(x) = x|x|$ at $x = 0$

- (a) is 0 .
- (b) does not exist, because $|x|$ is not differentiable at $x = 0$
- (c) does not exist, because f is defined piecewise
- (d) does not exist, because the left and right hand limits do not agree.

Answer: (a). Instructors should encourage the use of the limit definition of derivative; $f'(0) = 0$

7. [P] If $f'(a)$ exists, $\lim_{x \rightarrow a} f(x)$

- (a) it must exist, but there is not enough information to determine it exactly
- (b) equals $f(a)$
- (c) equals $f'(a)$
- (d) it may not exist

Answer: (b). If f is differentiable at a , it must be continuous at a , and therefore the limit equals $f(a)$. Many students will like answers (a) and (d).

8. [P] Your mother says “If you eat your dinner, you can have dessert.” You know this means, “If you don’t eat your dinner, you cannot have dessert.” Your calculus teacher says, “If f is differentiable at x , f is continuous at x .” You know this means
- (a) if f is not continuous at x , f is not differentiable at x .
 - (b) if f is not differentiable at x , f is not continuous at x .
 - (c) knowing f is not continuous at x , does not give us enough information to deduce anything about whether the derivative of f exists at x .

Answer: (a). This is a nice logic question. Ask students to give examples of continuous functions that are not differentiable. If you have done some other logic questions, this will probably be an easy question, otherwise, a short introduction/review to logic might be necessary.

9. [Q] A slow freight train chugs along a straight track. The distance it has traveled after x hours is given by a function $f(x)$. An engineer is walking along the top of the box cars at the rate of 3 mi/hr in the same direction as the train is moving. The speed of the man relative to the ground is
- (a) $f(x) + 3$
 - (b) $f'(x) + 3$
 - (c) $f(x) - 3$
 - (d) $f'(x) - 3$

Answer (b). Once the students realize that $f'(x)$ is the speed of the train after x hours, most of them will give the right answer.

10. [Q] Suppose $f'(x)$ exists for all x in (a, b) . Read the following four statements:
- (I) $f(x)$ is continuous on (a, b)
 - (II) $f(x)$ is continuous at $x = a$
 - (III) $f(x)$ is defined for all x in (a, b)
 - (IV) $f'(x)$ is differentiable on (a, b)
- (a) I and III
 - (b) I, II and III
 - (c) All of the above
 - (d) None of the above

(e) Only I

Answer: (a). Students will know that I holds. They might have questions about II and not be quite sure about III.

Derivatives (using differentiation rules)

1. [Q] $\frac{d}{dx}(e^7)$ equals

- (a) $7e^6$
- (b) e^7
- (c) 0

Answer: (c). Quick check. Students must see that e^7 is a constant.

2. [D] **True or False.** For all n and all x , $\frac{d}{dx}|x|^n = n|x|^{n-1}$.

Answer: *False.* Point out that for n -even and all n -odd, $n > 1$, the equation holds; but for all other n , $|x|^n$ is not differentiable at zero.

3. [P] $\lim_{x \rightarrow 1} \frac{x^{10} - 1}{x - 1}$

- (a) does not exist, because $\frac{0}{0}$ is not defined
- (b) equals 10, because it is exactly the derivative of x^{10} , at $x = 1$
- (c) equals 1, because $(1)^9 = 1$.

Answer: (b). Recall the limit definition of the derivative; then one can easily check (b). Some may be inclined to answer (a); also, some students might be able to get the right answer, 10, by factoring $x^{10} - 1$, and then simplifying. Answer (c) comes from a cancellation error that students may make.

4. [Q] Suppose you cut a slice of pizza from a circular pizza of radius r , as shown.

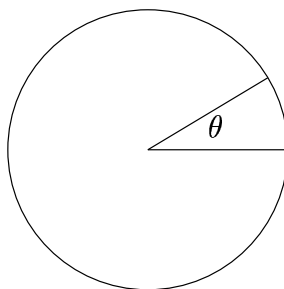

As you change the size of the angle θ , you change the area of the slice, $A = \frac{1}{2}r^2\theta$. Then A' is

- (a) $r\theta$
- (b) $\frac{1}{2}r^2$

(c) not possible to determine from the given information

Answer: (b). The area of the slice of pizza varies as the angle θ varies. The slice of pizza has area $A(\theta) = \frac{1}{2}r^2\theta$. Hence $A'(\theta) = \frac{1}{2}r^2$. Students should pay attention to the variable with respect to which they differentiate. Instructors may want to encourage their students to use the limit definition of the derivative in this problem.

5. [Q] The radius of a snowball changes as the snow melts. The instantaneous change in radius with respect to volume is

(a) $\frac{dV}{dr}$

(b) $\frac{dr}{dV}$

(c) $\frac{dV}{dr} + \frac{dr}{dV}$

(d) cannot be determined

Answer: (b). Quick check. This type of problem prepares students for later related rates problems.

6. [P] Gravel is poured into a conical pile. The rate at which gravel is added to the pile is

(a) $\frac{dV}{dt}$

(b) $\frac{dr}{dt}$

(c) $\frac{dV}{dr}$

(d) none of the above

Answer: (a). This may be a difficult question for students: it will be hard to figure out which quantity we need to differentiate, and with respect to what. Instructors should point out the difference between (a)-(c).

7. [Q] We know $f(1) = 1$ and $f'(1) = 3$. Then $\frac{d}{dx} \frac{f(x)}{x^2} \Big|_{x=1}$ equals

(a) 1

(b) $3/2$

(c) -1

Answer: (a). Straight forward application of quotient rule: $\frac{d}{dx} \frac{f(x)}{x^2} \Big|_{x=1} = \frac{f'(1) - 2f(1)}{1} = 1$

8. [P] Suppose that over an interval of time, Δt , the length, L , and width, W , of a rectangle grow to $L + \Delta L$ and $W + \Delta W$ respectively as in the sketch below.

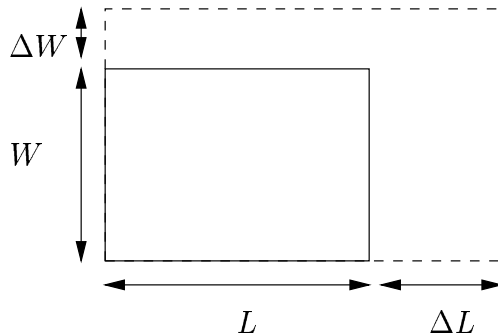

The average rate of change in A over the interval of time, Δt is

- (a) $\frac{LW}{\Delta t} + \frac{(\Delta L)(\Delta W)}{\Delta t}$
 (b) $\frac{LW}{\Delta t} + L\frac{\Delta W}{\Delta t} + W\frac{\Delta L}{\Delta t} + \frac{(\Delta L)(\Delta W)}{\Delta t}$
 (c) $L\frac{\Delta W}{\Delta t} + W\frac{\Delta L}{\Delta t}$
 (d) $L\frac{\Delta W}{\Delta t} + W\frac{\Delta L}{\Delta t} + \frac{(\Delta W)(\Delta L)}{\Delta t}$

Answer: (d). The answer follows from an easy computation:

$$\frac{\Delta A}{\Delta t} = \frac{L(\Delta W) + W(\Delta L) + (\Delta L)(\Delta W)}{\Delta t} = L\frac{\Delta W}{\Delta t} + W\frac{\Delta L}{\Delta t} + \frac{(\Delta W)(\Delta L)}{\Delta t}$$

9. [P] In the problem above, assume that L and W are differentiable functions of time, (i.e. $\frac{dL}{dt}$ and $\frac{dW}{dt}$ both exist for all t). The reason $\frac{dA}{dt}$ is the sum of the limits of the first two terms, and that the third term "disappears" when you take the limit is:

- (a) $\frac{dL}{dt}$ exists for each t and is some number, hence the limit of the third term is 0.
 (b) the terms in the numerator are both approaching 0, and therefore their product goes to 0 faster than the term in the denominator does
 (c) you can cancel one of the close to zero terms in the numerator with a close to zero term in the denominator, so the limit of the remaining term is 0
 (d) it is not possible to tell why the third term approaches 0.

Answer: (a). Students may be more comfortable using (b) or (c) as answers, even though they are wrong. This kind of problem should help them make the connection between $\frac{dL}{dt}$ and $\frac{\Delta L}{\Delta t}$.

$$\frac{dA}{dt} = \lim_{\Delta t \rightarrow 0} \frac{\Delta A}{\Delta t} = \lim_{\Delta t \rightarrow 0} \left[L\frac{\Delta W}{\Delta t} + W\frac{\Delta L}{\Delta t} + \Delta W\frac{\Delta L}{\Delta t} \right] = L\frac{dW}{dt} + W\frac{dL}{dt} + 0 \cdot \frac{dL}{dt}$$

10. [Q] The Constant Multiple Rule tells us

$$\frac{d}{dx}cf(x) = c\frac{d}{dx}f(x)$$

and the Product Rule says

$$\frac{d}{dx}cf(x) = c\frac{d}{dx}f(x) + f(x)\frac{d}{dx}c$$

True or **False**. The two rules agree. Be prepared to justify your answer.

Answer: True. Some students will be unable to recognize that we get the same result. Remind them that the derivative of a constant function is zero.

11. [P] $\lim_{x \rightarrow 0} \frac{\sin x}{x} = 1$ means that

- (a) $\frac{0}{0} = 1$
- (b) the tangent to the graph of $y = \sin x$ at $(0, 0)$ is the line $y = x$
- (c) you can cancel the x 's.
- (d) $\sin x = x$ for x near 0.

Answer: (b). Note that this is the derivative of $\sin x$ at 0, that is, the slope of the function $\sin x$ at 0 is 1. So the tangent to the graph $(0, 0)$ is the line $y = x$. Students will have trouble identifying the limit as a derivative, and also thinking of the derivative at 0 as the slope of the function (and of the tangent) at 0.

12. [Q] If $f(x) = \sin x$ then

- (a) $f(x) = f'''(x)$
- (b) $f(x) = -f''(x)$
- (c) $f'(x) = \cos(x)$
- (d) all of the above.

Answer: (d). This problem offers a chance to highlight some of the interesting periodic properties of the derivative of $\sin x$.

13. [Q] If $f(x) = \sin x \cos x$, $f'(x) =$

- (a) $1 - 2\sin^2(x)$
- (b) $2\cos^2(x) - 1$
- (c) $\cos 2x$
- (d) all of the above

(e) none of the above

Answer: (d). (a) - (c) are equivalent formulae. One can get (a) by using the product rule and $\cos^2(x) = 1 - \sin^2(x)$.

14. [Q] If $f(x) = \tan x$, $f'(x) =$

(a) $1 + \tan^2(x)$

(b) $\cot x$

(c) $-\cot x$

(d) all of the above

(e) none of the above

Answer: (a). $f'(x) = \sec^2(x) = 1 + \tan^2(x)$. (b)-(c) may arise if students compute the derivative in the following way: $\frac{d}{dx}(\tan x) = \frac{d}{dx}\left(\frac{\sin x}{\cos x}\right) = \frac{\cos x}{-\sin x}$.

15. [P] $\lim_{h \rightarrow 0} \frac{\sin(2x + h) - \sin(2x)}{h}$ equals

(a) $\cos x$

(b) $\cos(2x)$

(c) zero

(d) does not exist because $0/0$ is not defined

Answer: (b). $\lim_{h \rightarrow 0} \frac{\sin(2x + h) - \sin(2x)}{h} = \frac{d}{dy}(\sin y)|_{y=2x}$. This problem is making the connection between differentiation rules and the limit definition of derivative.

16. [D] We know that $\frac{d}{dx}(\sin x) = \cos x$. **True** or **False** $\frac{d}{dx} \sin(2x) = \cos(2x)$.

Answer: *False*. This is a nice preview of Chain Rule, also good exercise for a deep understanding of the limit definition of derivative. To be compared with the previous problem.

17. [P] $\frac{d}{dr}(\sin x + e^{\sin x})$ equals

(a) $\cos x + e^{\cos x}$

(b) $\cos x + e^{\sin x} \cos x$

(c) $\cos r + e^{\sin r} \cos r$

(d) not enough information

Answer: (d). There is not enough information since the missing factor, $\frac{dx}{dr}$ could be anything. If $x = r$, then (b) is correct. If x is constant with respect to r , then the answer is 0. Students may have difficulty considering $(\sin x + e^{\sin x})$ as a constant with respect to r .

18. [P] Suppose a deli clerk can slice a stick of pepperoni (assume the tapered ends have been removed) by hand at the rate of 2 inches per minute, while a machine can slice pepperoni at the rate of 10 inches per minute. Then $\frac{dV}{dt}$ for the machine is 5 times greater than $\frac{dV}{dt}$ for the deli clerk. This is explained by the

- (a) chain rule
- (b) product rule
- (c) quotient Rule
- (d) addition rule

Answer: (a). Straight forward application of chain rule if they have seen this type of problem before.

19. [Q] If f and g are both differentiable and $h = f \circ g$, $h'(2)$ equals

- (a) $f'(2) \circ g'(2)$
- (b) $f'(2)g'(2)$
- (c) $f'(g(2))g'(2)$
- (d) $f'(g(x))g'(2)$

Answer: (c). Even though students may have memorized the Chain Rule formula, some may not be able to apply it to this type of problem.

20. [P] The area of a circle, $A = \pi r^2$, changes as its radius changes. If the radius changes with respect to time, the change in area with respect to time is

- (a) $\frac{dA}{dr} = 2\pi r$
- (b) $\frac{dA}{dt} = 2\pi r + \frac{dr}{dt}$
- (c) $\frac{dA}{dt} = 2\pi r \frac{dr}{dt}$
- (d) not enough information

Answer: (c). This is an easy application of the Chain Rule; it prepares students for Related Rates problems.

21. [D] When you solve for y' in an implicit differentiation problem, you have to solve a quadratic equation
- (a) always
 - (b) sometimes
 - (c) never

Answer: (c). All equations in x and y can be written as a sum of terms of the form $f(x)g(y)$, and hence using implicit differentiation on this term,

$$\frac{d}{dx}f(x)g(y) = f'(x)g(y) + f(x)\frac{d}{dy}g(y) \cdot y'$$

hence no term in the sum has factors of the form $(y')^2$. Therefore, we never have to solve a quadratic. Students might be most comfortable answering (b), and if so, ask them first if they ever had to solve a quadratic while using implicit differentiation, and then go into more detail to why this does not happen.

22. [Q] If $g(x) = \sin^{-1} x$, then $g'(x)$ is

- (a) $\frac{1}{\sqrt{1-x^2}}$
- (b) $\frac{1}{\cos x}$
- (c) $-\frac{\cos x}{\sin^2 x}$
- (d) $\csc x \cot x$

Answer: (a). This example gives the instructor the opportunity to stress that $(\sin x)^{-1}$ is not the same as $\sin^{-1} x$.

23. [P] The slope of the line tangent to the graph of $x = \sin y$ at the point $(0, \pi)$ is

- (a) 1
- (b) -1
- (c) not defined

Answer: (b). Using implicit differentiation, $1 = \cos y \frac{dy}{dx}$. So at $(0, \pi)$, the slope is $\sec \pi = -1$. Students should note that even though this is not the graph of a function, it still has a tangent line at this point.

24. [Q] **True** or **False**. $\frac{d}{dx} \ln(\pi) = \frac{1}{\pi}$.

Answer: *False*. Students must observe that $\ln(\pi)$ is a constant, and thus $\frac{d}{dx} \ln(\pi) = 0$.

25. [Q] Your calculus book says that $e = \lim_{n \rightarrow \infty} \left(1 + \frac{1}{n}\right)^n$. This means:

- (a) e is not really a number because it is a limit
- (b) e cannot be computed
- (c) the sequence of numbers $\left(\frac{2}{1}\right), \left(\frac{3}{2}\right)^2, \left(\frac{4}{3}\right)^3, \dots, \left(\frac{101}{100}\right)^{100}, \dots$ get as close as you want to the number e

Answer (c). e can be approximated very well by taking a number that is extremely close to 1, and raising it to a high enough power. Students may be puzzled by this answer, since $\frac{2}{1}, \frac{3}{2}, \frac{4}{3}, \dots, \frac{101}{100}, \dots$ gets very close to 1, and "1 to any power is 1". This may be a good time to point out that 1^∞ is not defined. Note that (a) and (b) are also correct answers with the appropriate meanings, i.e., e is not a number in the sense that it cannot be written down or completely computed numerically.

26. [P] When you read in the newspaper thing like inflation rate, interest rate, birth rate, etc., it always means $\frac{f'}{f}$, not f' itself.

True or False. $\frac{f'}{f}$ is not the derivative of a function.

Answer: False. $\frac{f'}{f}$ is the derivative of $\ln |f|$. Students should check by differentiating.

Linear approximations and Differentials

1. [P] If e^5 is approximated by using the tangent line to the graph of $f(x) = e^x$ at $(0,1)$, and we know $f'(0) = 1$, the approximation is

- (a) .5
- (b) $1 + e^5$
- (c) $1 + .5$

Answer: (c). Most students will be able to get a correct formula for the linearization of e^x at 0, $L(x) = 1 + x$, but a good number will have difficulties knowing how to use this information to get an approximation for e^5 .

2. [Q] The line tangent to the graph of $f(x) = \sin x$ at $(0, 0)$ is $y = x$. This implies that

- (a) $\sin(.0005) \approx .0005$
- (b) The line $y = x$ touches the graph of $f(x) = \sin x$ at exactly one point, $(0, 0)$
- (c) $y = x$ is the best straight line approximation to the graph of f for all x

Answer: (a). If presented in the Linearization Approximation section, this problem will be straightforward for most students.

3. [P] The line $y = 1$ is tangent to the graph of $f(x) = \cos x$ at $(0, 1)$. This means that

- (a) the only x -values for which $y = 1$ is a good estimate for $y = \cos x$ are those that are close enough to 0
- (b) tangent lines can intersect the graph of f infinitely many times
- (c) the farther x is from 0, the worse the linear approximation is

Answer: (b). Students might be inclined to answer (a), since usually we use tangent line approximations for values of x close to a ; or they might choose (c), since the closer we are to a , the better the approximation will be, without realizing that we might get a good approximation even far from a .

4. [P] The error of using the tangent line $y = f(a) + f'(a)(x - a)$ to approximate $y = f(x)$ is $E(x) = f(x) - [f(a) + f'(a)(x - a)]$. Then

$$\lim_{x \rightarrow a} \frac{E(x)}{(x - a)}$$

- (a) must be 0
- (b) might not exist
- (c) depends on the value of a

Answer: (a). Students might need a hint: plug in the formula for $E(x)$ and then split the limit into two limits that you recognize and can compute.

$$\lim_{x \rightarrow a} \frac{E(x)}{(x-a)} = \lim_{x \rightarrow a} \frac{f(x) - f(a)}{(x-a)} - \lim_{x \rightarrow a} \frac{f'(a)(x-a)}{(x-a)} = f'(a) - f'(a) = 0$$

5. [D] Suppose you have two functions f and g shown below, and their tangent lines L_1 and L_2 .

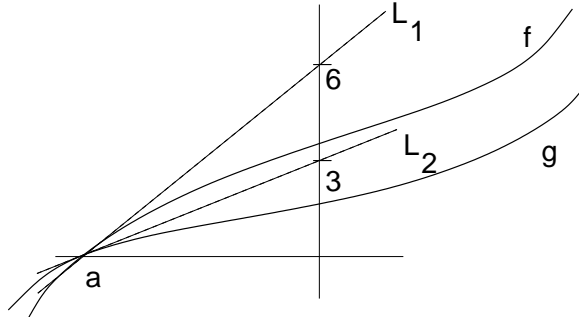

The $\lim_{x \rightarrow a} \frac{f(x)}{g(x)}$

- (a) is 2
- (b) does not exist, because $0/0$ does not exist
- (c) cannot be determined with this information. You need to know a
- (d) is 3

Answer: (a). Note that $f'(a)$ is equal to the slope of L_1 , and $g'(a)$ equals the slope of L_2 . $L_1(x) = f(a) + f'(a)(x-a) = f'(a)(x-a)$ and $L_2(x) = g(a) + g'(a)(x-a) = g'(a)(x-a)$. Using notation from number 4 above,

$$\begin{aligned} \lim_{x \rightarrow a} \frac{f(x)}{g(x)} &= \lim_{x \rightarrow a} \frac{L_1(x) + E_1(x)}{L_2(x) + E_2(x)} = \lim_{x \rightarrow a} \frac{f'(a)(x-a) + E_1(x)}{g'(a)(x-a) + E_2(x)} = \lim_{x \rightarrow a} \frac{f'(a) + \frac{E_1(x)}{(x-a)}}{g'(a) + \frac{E_2(x)}{(x-a)}} = \\ \frac{f'(a) + 0}{g'(a) + 0} &= \frac{f'(a)}{g'(a)} = \frac{\text{slope of } L_1}{\text{slope of } L_2} = 2 \end{aligned}$$

6. [Q] Suppose that $f''(x) < 0$ for x near a point a . Then the linearization of f at a is
- (a) an over approximation
 - (b) an under approximation
 - (c) unknown without more information.

Answer: (a). This will be clear for most students. Ask for a graph of such a function f and its tangent line approximation at some point a .

7. [Q] Peeling an orange changes its volume V . What does ΔV represent?

- (a) the volume of the rind
- (b) the surface area of the orange
- (c) the volume of the "edible part" of the orange
- (d) $-1 \times$ (the volume of the rind)

Answer: (a). ΔV represents the change in volume, hence it is the volume of the part that is being removed, i.e., the rind. This problem is a nice introduction to differentials. Note that (d) also works and may be a more natural derivation.

8. [P] If you divide the volume of the rind of a thin-skinned orange by the thickness of the rind you get a good estimate for

- (I) The surface area of the original orange
- (II) The surface area of the edible part
- (III) The change in the volume of the orange
- (IV) The square of the radius of the orange

- (a) I and II
- (b) III
- (c) I only
- (d) IV

Answer: (a). If you use this problem following number 2, III clearly does not apply, and IV does not hold because we need an additional constant factor of 4π . Since the skin is very thin, the radius of the orange R is approximately the radius of the edible part r , so are their respective surface areas. More exactly,

$$\frac{\Delta V}{\Delta x} = \frac{4}{3}\pi \frac{R^3 - r^3}{R - r} = \frac{4}{3}\pi(R^2 + rR + r^2) \approx 4\pi R^2 (\approx 4\pi r^2)$$

9. [P] Imagine that you increase the dimensions of a square with side x_1 to a square with side length x_2 . The change in the area of the square, ΔA , is approximated by the differential dA . In this example, dA is

- (a) $(x_2 - x_1)2x_1$
- (b) $(x_2 - x_1)2x_2$
- (c) $x_2^2 - x_1^2$
- (d) $(x_2 - x_1)^2$

Answer: (a). Since $A = x^2$, $dA = 2x dx$, where $dx = x_2 - x_1$. Thus, $dA = 2x_1(x_2 - x_1)$. Some students might think $dA = \Delta A = x_2^2 - x_1^2$ and answer (c). Others may plug in $x = x_2$ and thus answer (b).

10. [Q] Imagine that you increase the dimensions of a square with side x_1 to a square with side length x_2 . If you estimate the change in the area of the square, ΔA by the differential $dA = 2x_1(x_2 - x_1)$, this will result in an

- (a) overestimate
- (b) underestimate
- (c) exactly equal

Answer: (b). Note that $\Delta A = x_2^2 - x_1^2 = (x_2 + x_1)(x_2 - x_1) > 2x_1(x_2 - x_1) = dA$. This can also be shown by taking the second derivative.

Applications of Differentiation

Related Rates

1. [Q] As gravel is being poured into a conical pile, its volume V changes with time. As a result, the height h and radius r also change with time. Knowing that at any moment $V = \frac{1}{3}\pi r^2 h$, the relationship between the changes with respect to time in the volume, radius and height is

(a) $\frac{dV}{dt} = \frac{1}{3}\pi \left(2r \frac{dr}{dt} h + r^2 \frac{dh}{dt} \right)$

(b) $\frac{dV}{dt} = \frac{1}{3}\pi \left(2r \frac{dr}{dt} \cdot \frac{dh}{dt} \right)$

(c) $\frac{dV}{dr} = \frac{1}{3}\pi \left(2rh + r^2 \frac{dh}{dt} \right)$

(d) $\frac{dV}{dh} = \frac{1}{3}\pi \left((r^2)(1) + 2r \frac{dr}{dh} h \right)$

Answer: (a). Easy application of the Chain Rule + Product Rule.

2. [P] A boat is drawn close to a dock by pulling in a rope as shown. How is the rate at which the rope is pulled in related to the rate at which the boat approaches the dock?

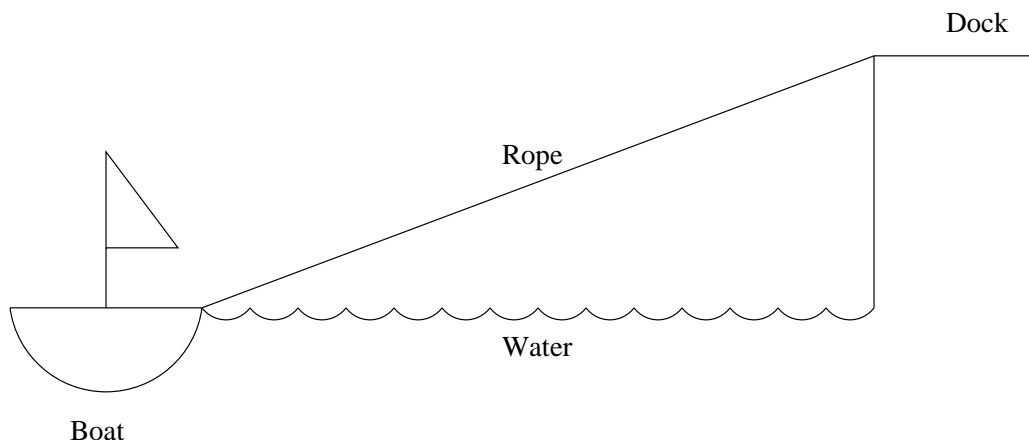

- (a) One is a constant multiple of the other.
(b) They are equal.
(c) It depends on how close the boat is to the dock.

Answer: (c). Let $z(t)$ be the length of the rope, and $x(t)$ be the horizontal distance from the boat to the dock. Then, using the Pythagorean Theorem, and differentiating, one gets: $z \frac{dz}{dt} = x \frac{dx}{dt}$, and the answer follows. This problem encourages the students to use their intuition, before writing down the mathematical model, as they start

thinking about a related rates problem. A good point can be made about the power of mathematics to supplement or test our intuition.

Note that answer (a) is correct in the case the boat is pulled in from a floating dock.

3. [P] A boat is drawn close to a dock by pulling in the rope at a constant rate. **True** or **False**. The closer the boat gets to the dock, the faster it is moving.

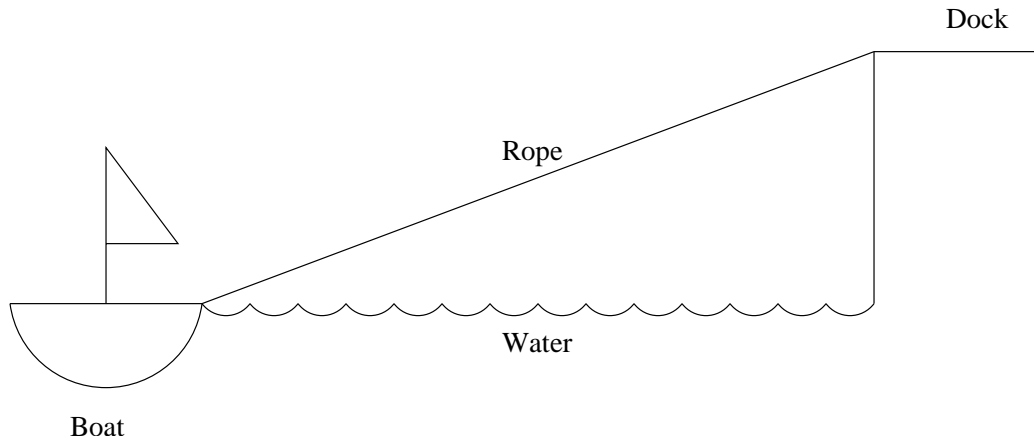

Answer: True. The answer to this problem becomes apparent after constructing the mathematical model. Using the Pythagorean theorem, one can get $x \frac{dx}{dt} = z \frac{dz}{dt}$ where z is the length of the rope, and x is the distance to the dock, as in the previous problem. So writing $\frac{dx}{dt} = \frac{z}{x} \frac{dz}{dt}$ we see that as $x \rightarrow 0$, $\frac{dx}{dt}$ increases. In fact, according to our model the boat will at some point be traveling faster than the speed of light! It will be interesting for the students to discuss why our model fails to describe what actually happens.

4. [P] A streetlight is mounted at the top of a pole. A man walks away from the pole. How are the rate at which he walks away from the pole and the rate at which his shadow grows related?

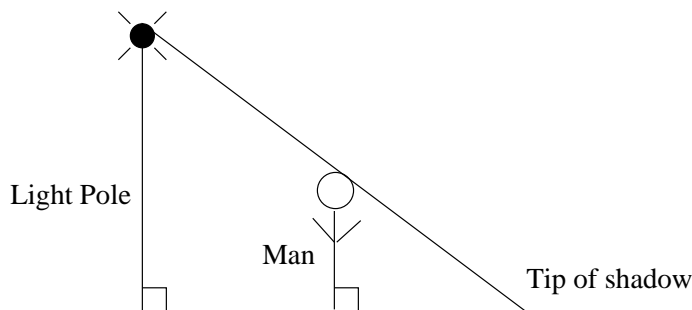

- (a) One is a constant multiple of the other.
 (b) They are equal.

(c) It depends also on how close the man is to the pole.

Answer: (a). Similar triangles and some knowledge of related rates, make this problem fairly easy to set up. The lack of numbers will help students concentrate on the idea of related rates. It is interesting to contrast this problem and the next one.

5. [P] A spotlight installed in the ground shines on a wall. A woman stands between the light and the wall casting a shadow on the wall. How are the rate at which she walks away from the light and rate at which her shadow grows related?

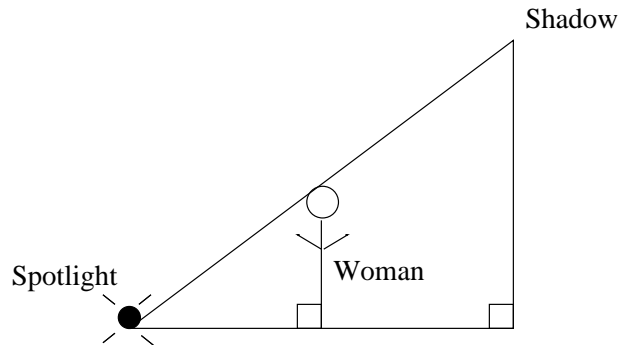

- (a) One is a constant multiple of the other.
(b) They are equal.
(c) It depends also on how close the woman is to the pole.

Answer: (c). This problem should be done after the one above. It helps students see that very similar problem set ups predict different outcomes.

Maximum and Minimum Values

1. [Q] **True or False.** If $f(x)$ is continuous on a closed interval, then it is enough to look at the points where $f'(x) = 0$ in order to find its absolute maxima and minima. Be prepared to justify your answer.

Answer: False. Encourage the students to think of the different ways in which this would fail -i.e. the endpoints, points where the derivative does not exist.

2. [P] Let $f(x)$ be a differentiable function on a closed interval with $x = a$ being one of the endpoints of the interval. If $f'(a) > 0$ then,
- (a) f could have either an absolute maximum or an absolute minimum at $x = a$.
(b) f cannot have an absolute maximum at $x = a$.
(c) f must have an absolute minimum at $x = a$.

Answer: (a). Students should think about the differences between local and absolute extrema. Ask students to draw pictures of functions satisfying $f'(a) > 0$, with a being the left endpoint, and then a being the right endpoint.

3. [P] Let f be a continuous function on the closed interval $0 \leq x \leq 1$. There exists a positive number A so that the graph of f can be drawn inside the rectangle $0 \leq x \leq 1$, $-A \leq y \leq A$.

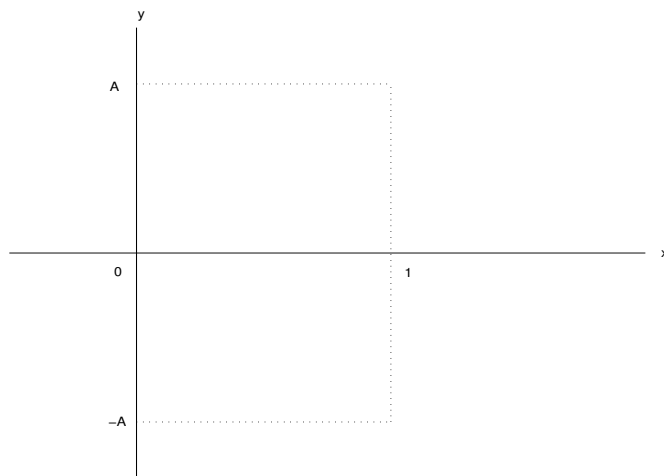

The above statement is:

- (a) Always true.
- (b) Sometimes true.
- (c) Not enough information.

Answer: (a). This problem emphasizes one important application of the EVT which is at the same time a very geometric result; that we can put a continuous function on a closed interval inside a box! On a closed interval, $m \leq f(x) \leq M$, so if we take $A = \max\{|m|, |M|\}$, then on this closed interval, f fits in this sort of box. This idea will ultimately show up in finding bounds for integrals, so it would be great to introduce this idea at this point.

4. [Q] Suppose you cut a slice of pizza from a circular pizza of radius r , as shown.

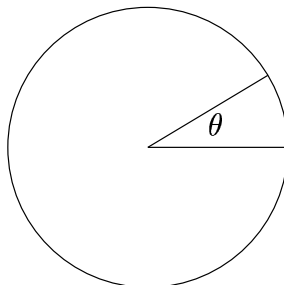

As you change the size of the angle θ , you change the area of the slice, $A = \frac{1}{2}r^2\theta$. Then $A' =$

- (a) $\frac{1}{2}r^2$
- (b) $r\theta + \frac{1}{2}r^2\frac{d\theta}{dr}$
- (c) $r\frac{d\theta}{dr}$
- (d) $r\frac{dr}{d\theta}\theta + \frac{1}{2}r^2$, and $\frac{dr}{d\theta}$ is not 0.

Answer: (a). The area of the slice of pizza is the area of a sector of angle θ , $A(\theta) = \frac{1}{2}r^2\theta$. Hence $A'(\theta) = \frac{1}{2}r^2$. Students should pay attention to the variable with respect to which they differentiate.

5. [D] Suppose you cut a slice of pizza from an amoeba shaped pizza, as shown.

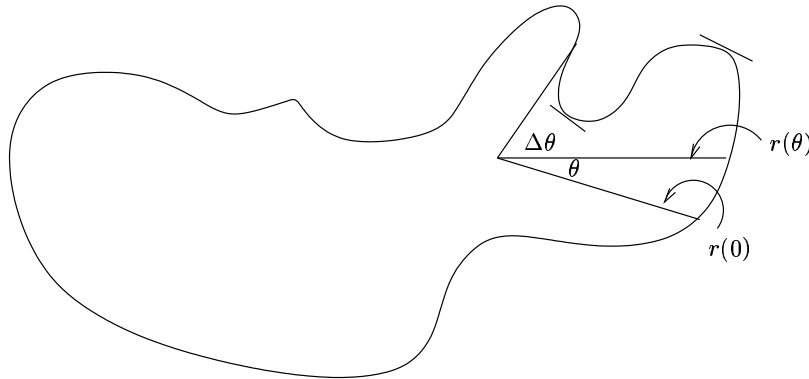

As you change the size of the angle θ , you change the area of the slice. Then $A'(\theta)$ is

- (a) Not enough information. You need an explicit function for the area
- (b) $\frac{1}{2}(r(\theta))^2$
- (c) $\frac{1}{2}(r(\theta))^2 + r(\theta)\frac{dr}{d\theta}\theta$

Answer: (b). This problem can be used after the instructor talks about absolute extrema in a closed interval. Using the definition of derivative, $A'(\theta) = \lim_{\Delta\theta \rightarrow 0} \frac{\Delta A}{\Delta\theta}$. We know that in a piece of pizza with angle $\Delta\theta$, the radius is always in $[r_{min}(\theta), r_{max}(\theta)]$ for some $r_{min}(\theta)$ and $r_{max}(\theta)$ (EVT). Hence

$$\frac{\frac{1}{2}(r_{min}(\theta))^2\Delta\theta}{\Delta\theta} \leq \frac{\Delta A}{\Delta\theta} \leq \frac{\frac{1}{2}(r_{max}(\theta))^2\Delta\theta}{\Delta\theta}$$

Since as $\Delta\theta \rightarrow 0$, $r_{min}(\theta) \rightarrow r(\theta)$ and $r_{max}(\theta) \rightarrow r(\theta)$, by the Squeeze Theorem, $A'(\theta) = \frac{1}{2}(r(\theta))^2$.

6. [D] As a tree grows, its trunk increases its volume by adding a growth ring, around the outside of the trunk (assume the thickness of the growth ring is the same over the whole trunk). The instantaneous rate of change in the volume of the trunk with respect to thickness of the growth ring is
- the circumference of the trunk.
 - the surface area of the trunk.
 - the thickness of the growth ring times the surface area of the trunk.

Answer: (b). The surface area of the trunk is between $[A_{min}, A_{max}]$, during the time in which the tree adds a ring of thickness Δx . Then,

$$\frac{A_{min}\Delta x}{\Delta x} \leq \frac{\Delta V}{\Delta x} \leq \frac{A_{max}\Delta x}{\Delta x}$$

As $\Delta x \rightarrow 0$, $A_{min} \rightarrow A$ and $A_{max} \rightarrow A$, where A is the surface area of the trunk. Therefore, $V'(x) = A(x)$.

7. [D] When you slice a loaf of bread, you change its volume. Let x be the length of the loaf from one end to the place where you cut off the last slice. Let $V(x)$ be the volume of the loaf of length x (see figure). For each x , $\frac{dV}{dx}$ is

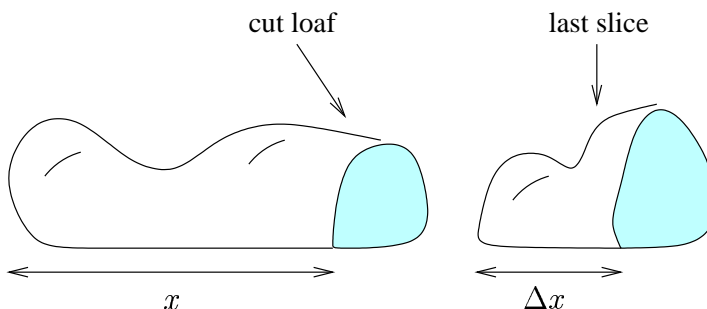

- the volume of a slice of bread
- the area of the cut surface of the loaf where the last slice was removed
- the volume of the last slice divided by the thickness of the slice.

Answer: (b). $\frac{dV}{dx} = \lim_{\Delta x \rightarrow 0} \frac{\Delta V}{\Delta x}$. As in the previous two problems, using the EVT, one can bound the surface area $A(x)$ of the last slice by $A_{min} \leq A(x) \leq A_{max}$. We get

$$\lim_{\Delta x \rightarrow 0} \frac{A_{min}\Delta x}{\Delta x} \leq \frac{dV}{dx} \leq \lim_{\Delta x \rightarrow 0} \frac{A_{max}\Delta x}{\Delta x}$$

Since again A_{min} and A_{max} approach $A(x)$ as $\Delta x \rightarrow 0$, $\frac{dV}{dx} = A(x)$.

Optimization

1. [Q] A designer wants to introduce a new line of bookcases: he wants to make at least 100 bookcases, but not more than 2000 of them. He predicts the cost of producing x bookcases is $C(x)$. Assume that $C(x)$ is a differentiable function. Which of the following must he do to find the minimum average cost, $c(x) = \frac{C(x)}{x}$?
 - (I) find the points where $c'(x) = 0$ and evaluate $c(x)$ there
 - (II) compute $c''(x)$ to check which of the critical points in (I) are local maxima.
 - (III) check the values of c at the endpoints of its domain.
 - (a) I only
 - (b) I and II only
 - (c) I and III only
 - (d) I, II and III

Answer: (c). Students tend to use the second derivative test without thinking, but in finding absolute extrema on a closed interval, it is not necessary. This also reminds students to check the endpoints in optimization problems.

2. [Q] You are given a continuous function, for which $f''(x) > 0$ for all reals, except at $x = a$.

True or False. f might have an absolute maximum at $x = a$.

Be prepared to give a counterexample or justify your answer.

Answer: True. Consider a function with a cusp at $x = a$ and $f(a) = 1$, which remains positive, and decreases to a horizontal asymptote at $y = 0$.

3. [Q] If f is continuous on $[a, b]$, then
 - (a) there must be numbers m and M such that $m \leq f(x) \leq M$, for $x \in [a, b]$
 - (b) there must be local extreme values, but there may or may not be an absolute maximum or absolute minimum value for the function.
 - (c) any absolute max or min would be at either the endpoints of the interval, or at places in the domain where $f'(x) = 0$

Answer: (a). (c) omits the possibility that the max or min could occur at a point on the graph where $f'(x)$ does not exist (such as a cusp), and (b) is false by the Extreme Value Theorem.

4. [D] You have a piece of wire of length L from which you construct a circle and/or a square in such a way that the total enclosed area is maximal. Then
 - (a) you should construct only the square

- (b) you should construct only the circle
- (c) you should construct both the square and the circle, but the perimeter of the square must be larger than the perimeter of the circle
- (d) you should construct both the square and the circle, but the perimeter of the square must be less than the perimeter of the circle

Answer: (b). If r is the radius of the circle, and x is the side of the square, $A = \pi r^2 + x^2$, and $L = 2\pi r + 4x$. After writing A as a function of r (or x), differentiating, testing at critical points and endpoints, one can easily see that we get a maximal enclosed area for $x = 0$ and $r = \frac{L}{2\pi}$. One can also reason geometrically, and students should be encouraged to use their intuition and think of a geometric argument before starting the analytic solution.

Notes for the Instructor: Students in this section have a hard time setting up the problem, so they need to practice for that. Here we tried to help them recall how to search for the absolute maxima and minima, and call their attention to often made mistakes.

Mean Value Theorem and shapes of curves

1. [P] An article in the Wall Street Journal's "Heard on the Street" column (*Money and Investment* August 1, 2001) reported that investors often look at the "change in the rate of change" to help them "get into the market before any big rallies." Your stock broker alerts you that the rate of change in a stock's price is increasing. As a result you
 - (a) can conclude the stock's price is decreasing
 - (b) can conclude the stock's price is increasing
 - (c) cannot determine whether the stock's price is increasing or decreasing.

Answer: (c). If f is the stock price, and we found out that f' is increasing, this does not lead to any conclusion about the monotonicity of f .

2. [P] Imagine that you are skydiving. The graph of your speed as a function of time from the time you jumped out of the plane to the time you achieved terminal velocity is
 - (a) increasing and concave up
 - (b) decreasing and concave up
 - (c) increasing and concave down
 - (d) decreasing and concave down

Answer: (c). Have students relate what they THINK is happening to the mathematical concepts. For example, some students might think that their speed increases at a faster rate, while others will see that the "terminal velocity" idea points to a slowing in the rate of increase.

3. [Q] **True or False.** If $f''(a) = 0$, then f has an inflection point at a .

Answer: False. Students tend to believe this is a true statement. Point out an example when the statement does not hold, $f(x) = x^4$ at $a = 0$ for example.

4. [D] Water is being poured into a "Dixie cup" (a standard cup that is smaller at the bottom than at the top). The height of the water in the cup is a function of the volume of water in the cup. The graph of this function is
 - (a) increasing and concave up
 - (b) increasing and concave down
 - (c) a straight line with positive slope.

Answer: (b). It is easy to see that the function is increasing: the more water we add, the bigger the height. To see that the function is concave down, observe that the instantaneous rate of change of the height with respect to the volume is decreasing: as the cup gets filled, for a fixed increment in water, we get smaller and smaller increments in height.

5. [P] On a toll road a driver takes a time stamped toll-card from the starting booth and drives directly to the end of the toll section. After paying the required toll, the driver is surprised to receive a speeding ticket along with the toll receipt. Which of the following best describes the situation?
- (a) The booth attendant does not have enough information to prove that the driver was speeding.
 - (b) The booth attendant can prove that the driver was speeding during his trip.
 - (c) The driver will get a ticket for a lower speed than his actual maximum speed.
 - (d) Both (b) and (c).

Be prepared to justify your answer.

Answer: (d). First answer this question in the easiest form, discussing instantaneous and average velocity - then go back and try to answer again in a way that allows the application of the mean value theorem easily. The fact that (c) is also true, can be shown by using a graph. This is probably the hardest part of the problem.

6. [Q] **True or False.** For $f(x) = |x|$ on the interval $[-\frac{1}{2}, 2]$, can you find a point c in $(-\frac{1}{2}, 2)$ such that

$$f'(c) = \frac{f(2) - f(-\frac{1}{2})}{2 - (-\frac{1}{2})}$$

Answer: False. This emphasizes the differentiability hypotheses when using the MVT (Note that $f(x)$ is not differentiable at 0).

7. [P] The region between two concentric circles of radius r_1 and r_2 is called an annulus. If $r_2 > r_1$, the area of the annulus is $\pi(r_2^2 - r_1^2)$.

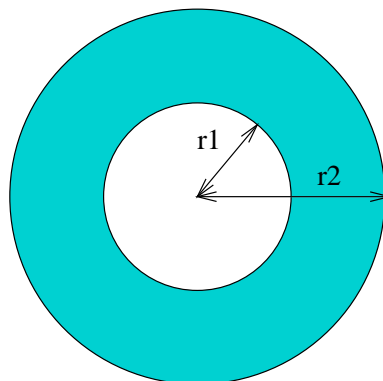

- (a) This area can be approximated by a sum of areas of rectangles, but there is no single rectangle that has exactly the same area.
- (b) This area cannot be approximated by the area of rectangles because the circles are concentric.
- (c) There must be a radius, r , between r_1 and r_2 for which the rectangle with base $r_2 - r_1$ and height $2\pi r$ is exactly equal to the area of the annulus.

Answer: (c). $\frac{A_2 - A_1}{r_2 - r_1} = \frac{\pi(r_2^2 - r_1^2)}{r_2 - r_1} = \pi(r_2 + r_1)$. On the other hand, by MVT, $\frac{A_2 - A_1}{r_2 - r_1} = 2\pi r$ for some $r \in (r_1, r_2)$. Thus, $A_2 - A_1 = 2\pi r(r_2 - r_1)$. This problem is a fairly simple application of the MVT, and the fact that you can get the answer to be exactly the area of that rectangle will probably surprise students. This problem will be a good reference later on, when we are trying to prove the evaluation part of the FTC.

8. **[Q]** A racer is running back and forth along a straight path. He finishes the race at the place where he began.

True or False. There had to be at least one moment, other than the beginning and the end of the race, when he "stopped" (i.e., his speed was 0). Be prepared to give a proof or counterexample.

Answer: True. It might be a bit hard for students to think of the model, but this problem is a good preparation for the much harder problem that follows. Note that the IVT could have also been used, by arguing that the velocity was during one part of the race positive and then it became negative.

9. **[D]** Two racers start a race at the same moment and finish in a tie. Which of the following must be true?

- (a) At some point during the race the two racers were not tied.
- (b) The racers' speeds at the end of the race must have been exactly the same.
- (c) The racers must have had the same speed at exactly the same time at some point in the race.
- (d) The racers had to have the same speed at some moment, but not necessarily at exactly the same time.

Answer: (c). This is a challenging problem for students. The main point here is to recall the idea (that was first introduced to them in the IVT) that we can show that two functions take the same value at a point by showing that their difference is zero. As the MVT only talks about what happens to one function, then we must look at the difference of the two functions in order to compare them at the same moment. Also discussing the problem with a graph, and showing that this happens when the slower person begins to speed up to catch up the other one will make it more clear.

10. [D] A solid cone with a circular base is sliced parallel to its base. The top and bottom of each slice are circles of radius r_1 and r_2 , say $r_2 > r_1$.
- (a) The volume of this slice can be approximated by the volume of a cylinder with the same thickness as the slice, but there is not necessarily a cylinder that has exactly the same volume as the slice.
 - (b) The volume of the slice cannot be approximated by the volume of a cylinder because the circles do not have the same radius.
 - (c) There must be a radius, r , between r_1 and r_2 for which the volume of the cylinder of radius, r , with height equal to the thickness of the slice is exactly equal to the volume of the slice.

Answer: (c). The volume of the cone of radius r and height h is $V(h) = \frac{\pi}{3}r^2h$. Looking at similar triangles, $r = h\frac{r_1}{h_1}$; thus, $V(h) = \frac{\pi}{3}h^3\left(\frac{r_1}{h_1}\right)^2$ and $V'(h) = \pi h^2\left(\frac{r_1}{h_1}\right)^2 = \pi r^2$. Now using the MVT,

$$\frac{\Delta V}{\Delta h} = \frac{V(h_2) - V(h_1)}{h_2 - h_1} = V'(h_*) = \pi(r_*)^2$$

for some $h_* \in [h_1, h_2]$ and corresponding $r_* \in [r_1, r_2]$. Therefore, the volume of the slice is $\Delta V = \pi(r_*)^2\Delta h$, equal to the volume of a cylinder of height Δh and radius r_* .

L' Hospital's Rule

1. [Q] Consider the functions $f(x) = e^x$ and $g(x) = x^{1,000,000}$. As $x \rightarrow \infty$ which of the following is true?
- (a) f grows faster than g .
 - (b) g grows faster than f .
 - (c) We cannot determine.
 - (d) They grow at the same rate like all exponentials.

Answer: (a). A repeated use of L' Hospital's Rule on their ratio gives the result.

2. [Q] The limit $\lim_{x \rightarrow \infty} [xe^{1/x} - x]$
- (a) Does not exist because $\infty - \infty$ is not defined.
 - (b) Converges to 1.
 - (c) Is ∞ because $xe^{1/x}$ grows faster than x .
 - (d) Converges to 0.

Answer: (b). An application of L' Hospital to $\infty - \infty$ type of limits.

$$\lim_{x \rightarrow \infty} [xe^{1/x} - x] = \lim_{x \rightarrow \infty} \frac{e^{1/x} - 1}{1/x} = \lim_{x \rightarrow \infty} e^{1/x} = 1$$

3. [Q] Suppose you have two functions f and g , with linear approximations L_1 and L_2 at $x = a$ as shown below.

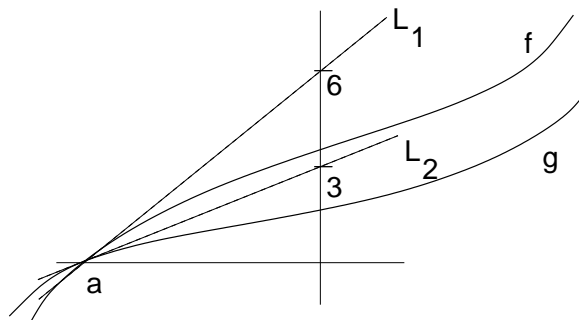

Then $\lim_{x \rightarrow a} \frac{f(x)}{g(x)}$ is

- (a) 2
- (b) Does not exist

(c) Not enough information

(d) 3

Answer (a). Here the student can notice that the linear approximation to the functions is enough (when the slopes are both non-zero) to give their relative rate of change at a point. We have seen before the same problem, but with just the lines. This will give more geometric intuition as to why L' Hospital's Rule works.

$$\lim_{x \rightarrow a} \frac{f(x)}{g(x)} = \lim_{x \rightarrow a} \frac{f'(x)}{g'(x)} = \frac{\text{slope of } L_1}{\text{slope of } L_2} = 2$$

Newton's Method

1. [Q] We will use each of the x_n below as the starting point for Newton's method. For which of them do you expect Newton's method to work and lead to the root of the function?

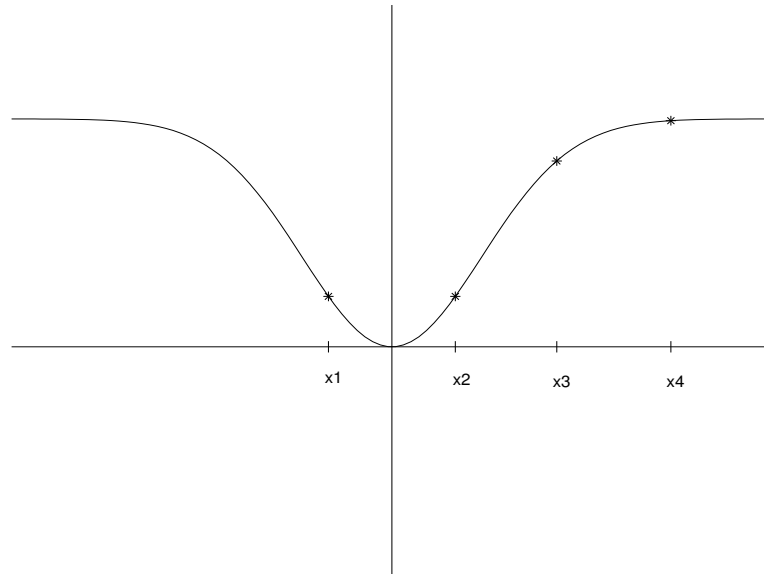

- (a) x_1 and x_2 only.
- (b) x_2 only.
- (c) x_1 , x_2 and x_3 only.
- (d) All four.

Answer: (c). A quick check see how Newton's method works graphically.

2. [Q] Let f be a differentiable function defined for all x . Starting Newton's method at a point c where $f'(c) = 0$ is:
- (a) A good idea, because $x = c$ is a critical point so Newton's method will lead us straight to the root.
 - (b) Is usually a bad idea because we might get stuck.
 - (c) It could work if we are lucky.
 - (d) Both (b) and (c).

Answer: (d). Being lucky means that c is already the root of the function. A graphical explanation would make it very clear.

3. [Q] Newton's method is a cool technique, because:

- (a) It can help us get decimal representations of numbers like $\sqrt[4]{3}$, $\sqrt[8]{5}$ and $\sqrt[5]{13}$
- (b) It can be used to find a solution to $x^7 = 3x^3 + 1$
- (c) Both (a) and (b).

Answer: (c). Quick check of when we use Newton's method.

Antiderivatives

1. [P] Suppose you are told that the acceleration function of an object is a continuous function $a(t)$. Let's say you are given that $v(0) = 1$.

True or False: You can find the position of the object at any time t .

Answer: False. The goal is to test whether students understand that they need one initial condition for each antiderivative they have to find.

2. [P] Let $f(x) = \frac{1}{x^2}$, and $F(x)$ be an antiderivative of f with the property $F(1) = 1$.
True or False. $F(-1) = 3$.

Answer: False. $f(x)$ is not continuous at 0! This problem may help them remember the continuity condition in finding antiderivatives. Students are almost surely going to answer true, and the answer will surprise them.

3. [Q] If f is an antiderivative of g , and g is an antiderivative of h , then

- (a) h is an antiderivative of f
- (b) h is the second derivative of f
- (c) h is the derivative of f''

Answer: (b). This follows from the definition of antiderivative. This kind of problem makes the connection between antiderivatives and derivatives.

4. [Q] **True or False:** An antiderivative of a sum of functions, $f + g$, is an antiderivative of f plus an antiderivative of g .

Answer: True. This is an easy check based on the text reading.

5. [P] **True or False:** An antiderivative of a product of functions, fg , is an antiderivative of f times an antiderivative of g .

Answer: False. Students should differentiate an antiderivative of f times an antiderivative of g , to see that they will not get fg back.

Integration

Areas, Distances, Riemann Sums

1. [Q] **True** or **False**. If a piece of string has been chopped into n small pieces and the i^{th} piece is Δx_i inches long, then the total length of the string is exactly $\sum_{i=1}^n \Delta x_i$.

Answer: True. This problem helps students to use the summation notation to represent physical quantities. It also gets the students to distinguish between the estimating procedure of a Riemann Sum versus cases in which we can have an exact value.

2. [P] You want to estimate the area underneath the graph of a positive function by using four rectangles of equal width. The rectangles that must give the best estimate of this area are those with height obtained from the:
- (a) Left endpoints
 - (b) Midpoints
 - (c) Right endpoints
 - (d) Not enough information

Answer: (d). Students often hold onto the idea that the midpoint estimate is the best. With this example the instructor can point out that there are cases in which it does not work as well as some of the other height choices. A specific function which has a long thin spike at the midpoint is a good counterexample.

3. [P] Suppose you are slicing an 11 inch long carrot REALLY thin from the greens end to the tip of the root. If each slice has a circular cross section $f(x) = \pi(r(x))^2$ for each x between 0 and 11, and we make our cuts at $x_1, x_2, x_3, \dots, x_n$, then a good approximation for the volume of the carrot is
- (a) $\sum_{i=1}^n f(x_i)x_i$
 - (b) $\sum_{i=1}^n [f(x_{i+1}) - f(x_i)]x_i$
 - (c) $\sum_{i=1}^n f(x_i)[x_{i+1} - x_i]$

Answer: (c). This is a quick application of the area approximations in this section. Once students understand the set up of the problem, the right answer should follow immediately from the text reading.

Class Activities

The following activities are designed to get the students to practice with the idea of estimating, as well as setting up a Riemann Sum, starting with tangible examples.

- (a) A boneless baked turkey breast that is ten inches long from one end to the other is sliced up in to very thin slices. Each slice has a cross-sectional area of $(-x^2 + 10x)$ square inches for each x between 0 and 10. What is the volume of the turkey breast?
- (b) Suppose you slice the carrot the long way? What shape slices would you expect (approximately)? How could you set up an expression for the volume of the whole carrot?

4. [Q] Let f be a continuous function on the interval $[a, b]$. **True or False:**

$$\lim_{n \rightarrow \infty} \sum_{i=1}^n f(x_i^*) \Delta x.$$

may lead to different limits if we choose the x_i^* to be the left-endpoints instead of midpoints.

Answer: False. This problem will remind the students that when we are taking the limit as n goes to infinity, we can choose any sample points that we want. Instructors should point out that even though the limits are the same, the corresponding sequences for approximations are not equally good.

5. [Q] **True or False.** If f is continuous on the interval $[a, b]$, then $\int_a^b f(x) dx$ is a number.

Answer: True. This problem emphasizes the difference between definite and indefinite integrals.

6. [P] Read the following four statements and choose the correct answer below.

If f is continuous on the interval $[a, b]$, then:

- (i) $\int_a^b f(x) dx$ is the area bounded by the graph of f , the x -axis and the lines $x = a$ and $x = b$
- (ii) $\int_a^b f(x) dx$ is a number
- (iii) $\int_a^b f(x) dx$ is an antiderivative of $f(x)$
- (iv) $\int_a^b f(x) dx$ may not exist
- (a) (ii) only
- (b) (i) and (ii) only

(c) (i) and (iii) only

(d) (iv) only

Answer: (a). This problem attempts to clarify most of the misconceptions that students have about definite integrals, and to help them move away from the idea that they always represent the area under a curve.

7. [P] Water is pouring out of a pipe at the rate of $f(t)$ gallons/minute. You collect the water that flows from the pipe between $t = 2$ and $t = 4$. The amount of water you collect can be represented by:

(a) $\int_2^4 f(x)dx$

(b) $f(4) - f(2)$

(c) $(4 - 2)f(4)$

(d) the average of $f(4)$ and $f(2)$ times the amount of time that elapsed

Answer: (a). This question might also help students see the definite integral as total change rather than the standard area interpretation. At the same time it differentiates it from averages.

8. [D] We cut a circular disk of radius r into n circular sectors, as shown in the figure, by marking the angles θ_i at which we make the cuts ($\theta_0 = \theta_n$ can be considered to be the angle 0). A circular sector between two angles θ_i and θ_{i+1} has area $\frac{1}{2}r^2 \Delta\theta$ where $\Delta\theta = \theta_{i+1} - \theta_i$.

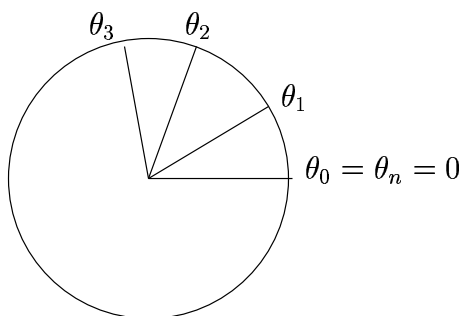

We let $A_n = \sum_{i=0}^{n-1} \frac{1}{2}r^2 \Delta\theta$. Then the area of the disk, A , is given by:

(a) A_n , independent of how many sectors we cut the disk into.

(b) $\lim_{n \rightarrow \infty} A_n$

(c) $\int_0^{2\pi} \frac{1}{2}r^2 d\theta$

(d) all of the above

Answer: (d). Recall the pizza problem (#4 in Section 3.1, #4 in Section 4.2). Students should easily see that (b) and (c) are equivalent. However, $\lim_{n \rightarrow \infty} A_n = A$ for all n . There is a point to be made about smarter and more efficient ways to estimate integrals, other than doing it with rectangles. The instructor should demonstrate to the students that the sum of the areas of sectors is the area of the whole disk.

9. [P] Suppose we cut a disk of radius R using n concentric circles, each one of radius r_i (see the figure below and let $r_0 = 0$). We have seen in the MVT problem, that between two radii r_i and r_{i+1} , there exists a radius \bar{r}_i such that the area of the annulus between r_i and r_{i+1} is exactly $2\pi\bar{r}_i(r_{i+1} - r_i)$. Letting $A_n = \sum_{i=0}^{n-1} 2\pi\bar{r}_i(r_{i+1} - r_i)$, then the area of the disk, A , equals:

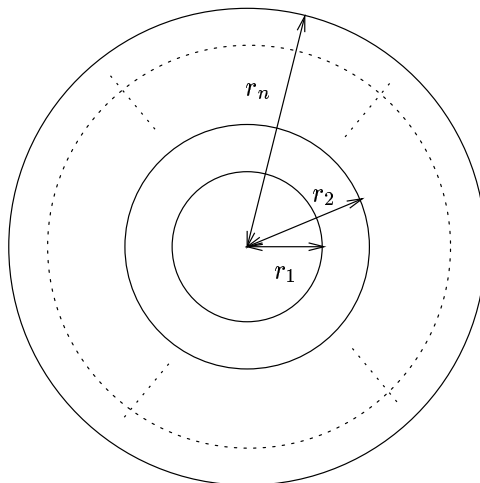

- (a) A_n , for all n
- (b) $\lim_{n \rightarrow \infty} A_n$
- (c) $\int_0^R 2\pi r dr$
- (d) all of the above

Answer: (d). See explanation for previous problem. Students should note the difference in expressions for A_n and integrals in the 2 problems above.

10. [P] Suppose we are going to consider the disk of radius r as the region bounded between the graphs of the functions $\sqrt{r^2 - x^2}$, and $-\sqrt{r^2 - x^2}$. Which of the following statements is true?

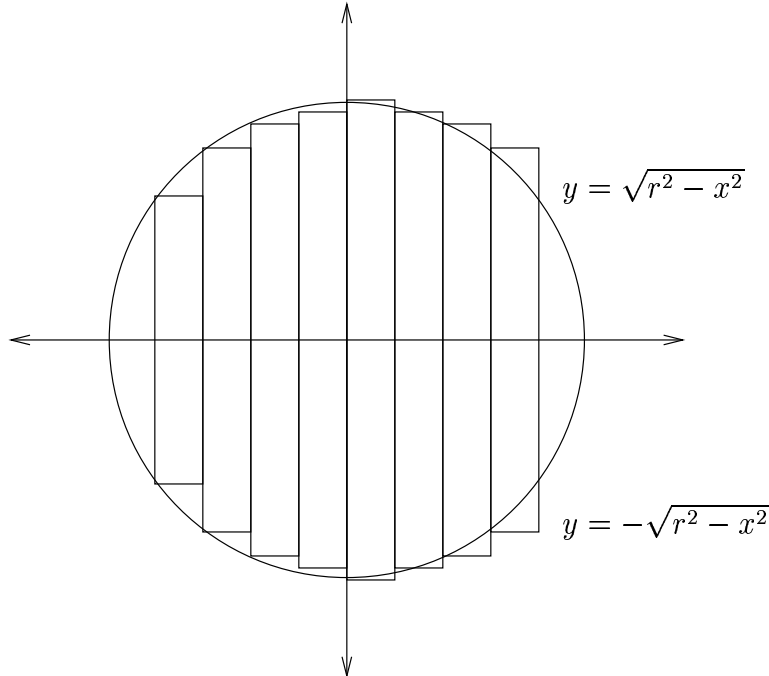

- (a) The area of the region is given by the formula: $\int_{-r}^r 2\sqrt{r^2 - x^2} dx$
- (b) The area of the disk can be written as a the limit of Riemann Sums of rectangles of length Δx and height $2\sqrt{r^2 - x_i^2}$ where the x_i are a partition of the interval $[-r, r]$.
- (c) Both (a) and (b).
- (d) The area cannot be found this way, because we cannot integrate the function $\sqrt{r^2 - x^2}$.

Answer: (c). A point should be made, that this 'standard' way of finding integrals, is actually much harder to calculate as is requires a special kind of substitution.

Evaluating Definite Integrals

- [Q] A sprinter practices by running various distances back and forth in a straight line in a gym. Her velocity at t seconds is given by the function $v(t)$. What does $\int_0^{60} |v(t)| dt$ represent?
 - The total distance the sprinter ran in one minute
 - The sprinter's average velocity in one minute
 - The sprinter's distance from the starting point after one minute
 - None of the above

Answer: (a). Another quick check of what the definite integral measures. Instructors should differentiate between this integral and $\int_0^{60} v(t) dt$, in order to emphasize the difference between displacement and distance traveled.

2. [P] Suppose f is a differentiable function. Then $\int_0^x f'(t) dt = f(x)$
- (a) Always
 - (b) Sometimes
 - (c) Never

Justify your answer.

Answer: (b). This problem is to test whether students understand the difference between definite and indefinite integrals. The instructor should bring to their attention, that the answer they would write down in case $f(0) = 0$ would be the same.

The following 2 problems to be used in a sequence:

3. **True or False.** If $\int f(x) dx = \int g(x) dx$, then $f(x) = g(x)$.

Answer: True. See below

4. **True or False.** If $f'(x) = g'(x)$, then $f(x) = g(x)$.

Answer: False. As students often get confused in the mechanics of the process of going back and forth between functions, their derivatives and antiderivatives, a discussion using the above problem can help them clarify their misunderstandings.

5. [P] Suppose the function $f(t)$ is continuous and always positive. If G is an antiderivative of f , then we know that G :

- (a) is always positive.
- (b) is sometimes positive and sometimes negative.
- (c) is always increasing.
- (d) There is not enough information to conclude any of the above.

Answer: (c). f is the derivative of G , thus $f > 0$ implies $G' > 0$, and therefore G is increasing. This is to demonstrate to students that they can apply the Increasing/Decreasing Test outside the context of problems like those in Chapter 4. Note that here we are just referring to the antiderivative of f . (a) may be a popular answer since we think of an integral of a positive function as "adding" positive small pieces. But the choice between (a) or (b) for a particular antiderivative G , depends on the constant.

The Fundamental Theorem of Calculus

1. [Q] If f is continuous and $f(x) < 0$ for all $x \in [a, b]$, then $\int_a^b f(x)dx$
- (a) must be negative
 - (b) might be 0
 - (c) not enough information

Answer: (a). Follows directly from properties of the integral.

2. [P] Let f be a continuous function on the interval $[a, b]$. **True** or **False**. There exist two constants m and M , such that $m(b - a) \leq \int_a^b f(x)dx \leq M(b - a)$

Answer: *True*. This is an immediate application of the Extreme Value Theorem. It is easily seen via an area argument (fitting the graph of f inside a box).

3. [Q] **True** or **False**. If f is continuous on the interval $[a, b]$, $\frac{d}{dx} \left(\int_a^b f(x)dx \right) = f(x)$.

Answer: *False*. Students often do not realize that definite integrals evaluated at constant endpoints a and b are constant, and in order to apply the FTC one must have one at least one of the endpoints as a variable. Note that if a and/or b were defined as functions of x , then the answer would be *True*.

4. [P] Below is the graph of a function f .

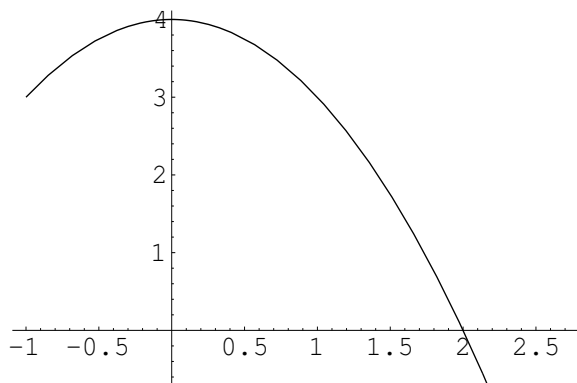

Let $g(x) = \int_0^x f(t) dt$. Then for $0 < x < 2$, $g(x)$ is

- (a) increasing and concave up.
- (b) increasing and concave down.
- (c) decreasing and concave up.
- (d) decreasing and concave down.

Answer: (b). This problem can help students realize that an integral of this form is a specific function (not a general antiderivative), and the integrand is its derivative. Students can induce information about the concavity of g just like they normally would with any other function, only that this time they have to look at f .

5. [P] Below is the graph of a function f .

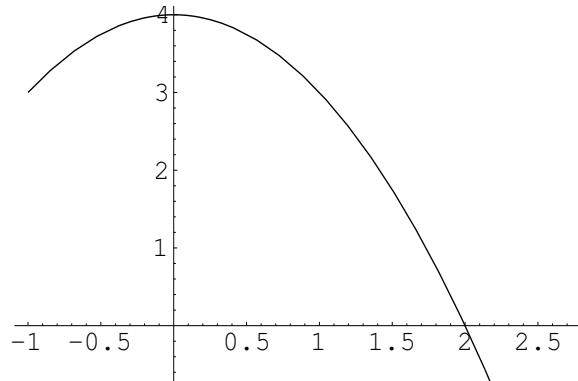

Let $g(x) = \int_0^x f(t) dt$. Then

- (a) $g(0) = 0$, $g'(0) = 0$ and $g'(2) = 0$
- (b) $g(0) = 0$, $g'(0) = 4$ and $g'(2) = 0$
- (c) $g(0) = 1$, $g'(0) = 0$ and $g'(2) = 1$
- (d) $g(0) = 0$, $g'(0) = 0$ and $g'(2) = 1$

Answer: (b). $g(0) = 0$, $g'(0) = f(0) = 4$, and $g'(2) = f(2) = 0$.

6. [P] You are traveling with velocity $v(t)$ that varies continuously over the interval $[a, b]$ and your position at time t is given by $s(t)$. Which of the following represent your average velocity for that time interval:

- (I) $\frac{\int_a^b v(t) dt}{(b-a)}$
 - (II) $\frac{s(b) - s(a)}{b-a}$
 - (III) $v(c)$ for at least one c between a and b
- (a) I, II, and III
 - (b) I only
 - (c) I and II only

Answer: (a). This is a great problem to put together the standard definition of the average velocity, the MVT and also the representation of total distance traveled from integration. It also introduces them to the MVT for integrals.

Integration Tools (Substitution Rule)

1. [Q] The differentiation rule that helps us understand why the Substitution rule works is:

- (a) The product rule.
- (b) The chain rule.
- (c) Both of the above.

Answer: (b). It will probably help students to remember where the Substitution rule comes from, instead of simply memorizing a rule.

2. [D] The area of a circular cell changes as a function of its radius, r , and its radius changes with time $r = g(t)$. If $\frac{dA}{dr} = f(r)$, then the total change in area, ΔA between $t = 0$ and $t = 1$ is

- (a) $\Delta A = \int_{\pi(g(0))^2}^{\pi(g(1))^2} dA$
- (b) $\Delta A = \int_{g(0)}^{g(1)} f(r) dr$
- (c) $\Delta A = \int_0^1 f(g(t))g'(t) dt$
- (d) all of the above

Answer: (d). This is an immediate consequence of the substitution rule. At time $t = 0$, $A = \pi(g(0))^2$ and at $t = 1$, $A = \pi(g(1))^2$. So (a) follows. We get (b) from $dA = f(r) dr$, and (c) from $dA = f(r) dr = f(g(t))g'(t) dt$.

3. [P] The radius, r , of a circular cell changes with time t . If $r(t) = \ln(t + 2)$, which of the following represent the change in area, ΔA , of the cell that occurs between $t = 0$ and $t = 1$?

- (a) $\Delta A = \pi(\ln 3)^2 - \pi(\ln 2)^2$
- (b) $\Delta A = \int_{\ln 2}^{\ln 3} 2\pi r dr$
- (c) $\Delta A = \int_0^1 2\pi \frac{\ln(t+2)}{t+2} dt$
- (d) all of the above

Answer: (d). This is an application of the previous problem. $A(t) = \pi r^2 = \pi(\ln(t+2))^2$; at $t = 0$, $r(t) = \ln 2$, and at $t = 1$, $r(t) = \ln 3$. Then (a) clearly follows. (b) holds since $A'(r) = 2\pi r$, and thus $\Delta A = \int_{\ln 2}^{\ln 3} A'(r) dr$. (c) follows from $\Delta A = \int_0^1 A'(t) dt$.

4. [P] One way to compute $1/2$ area of the unit circle is to integrate $\int_{-1}^1 \sqrt{1-x^2} dx$.

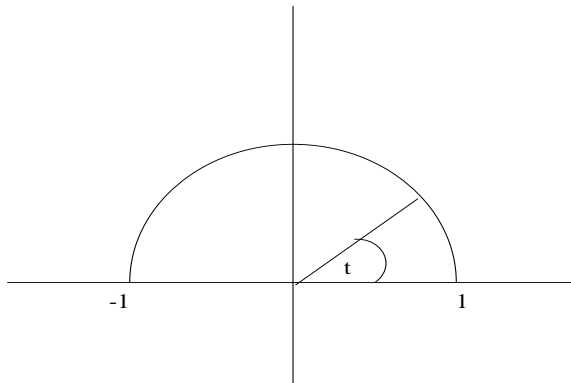

Let t be the angle shown. Then the area of the half circle is

- (a) $\int_0^\pi -\sin t dt$
- (b) $\int_0^\pi -\sin^2 t dt$
- (c) $\int_\pi^0 -\sin^2 t dt$
- (d) $\int_0^\pi -\cos t dt$

Answer: (c). If we let $y = \sin t$, and $x = \cos t$, then $dx = -\sin t dt$. When $x = -1$, $t = \pi$ and $x = 1$, $t = 0$; therefore, $A = \int_\pi^0 -\sin^2 t dt$.